

 <p>M.D. Micro Detectors Strada S. Caterina, 235 41122 Modena Italy Tel. +39 059 420411 Fax +39 059 253973 www.microdetectors.com info@microdetectors.com</p>	LS2 SERIES SAFETY LIGHT CURTAIN TYPE 2		LANGUAGE
	Installation and Operation Manual		ENGLISH



 Micro Detectors Italian Sensors Technology	M.D. Micro Detectors Strada S. Caterina, 235 41122 Modena Italy Tel. +39 059 420411 Fax +39 059 253973 www.microdetectors.com info@microdetectors.com	LS2 SERIES SAFETY LIGHT CURTAIN TYPE 2	LANGUAGE
		Installation and Operation Manual	

CONTENTS

1.0	ABOUT THIS DOCUMENT	3
1.1	Function of this document	3
1.2	Symbols used in this document.....	3
2.0	WITH REFERENCE TO SAFETY	4
2.1	Skilled personnel	4
2.2	Fields of use of the device	4
2.3	General safety instructions and measures of protection.....	5
2.4	Disposal.....	5
3.0	DESCRIPTION OF THE PRODUCT	5
3.1	Brief description	5
3.2	Coding system.....	6
3.3	Availability of models with IP65 + IP67 protection	7
3.4	Availability of models with IP69K protection	7
3.5	Possibility of interconnection of the available models	8
4.0	INSTRUCTIONS FOR POSITIONING THE SAFETY LIGHT CURTAINS	9
4.1	Respecting the safety distance.....	9
4.2	How to calculate the safety distance S in conformity with EN ISO 13855 and EN ISO 13857	10
5.0	MINIMUM DISTANCE FROM REFLECTING SURFACES	13
5.1	How to calculate the minimum distance from reflective surfaces	13
6.0	COMMISSIONING	14
6.1	Mechanical mounting.....	14
6.2	Alignment	14
6.3	Electrical installation.	15
7.0	TECHNICAL SPECIFICATIONS.	19
8.0	PANEL AND DIAGNOSTICS INDICATIONS	20
8.1	Symbols used to indicate the LED indicators modes.....	20
8.2	Indications of the panels	20
8.3	Interpretation of error codes	21
9.0	LISTS OF AVAILABLE MODELS AND MAIN CHARACTERISTICS	22
10.0	MECHANICAL DIMENSIONS, BARRIERS AND STANDARD ACCESSORIES	29
10.1	IP67 models	29
10.2	IP69K models	31
11.0	LIST OF ACCESSORIES APPLICABLE TO THIS PRODUCT	32
12.0	CONTENT OF THE PACKAGE	32
13.0	CHECKING THE SYSTEM	33
13.1	Purpose of the checks.....	33
13.2	Checks prior to commissioning.....	33
13.3	Regularity of the checks by qualified personnel	33
13.4	Regular checks on the effectiveness of the protection device.....	33
14.0	CE DECLARATION OF CONFORMITY	33
15.0	GUARANTEE	34

 <p>M.D. Micro Detectors Strada S. Caterina, 235 41122 Modena Italy Tel. +39 059 420411 Fax +39 059 253973 www.microdetectors.com info@microdetectors.com</p>	LS2 SERIES SAFETY LIGHT CURTAIN TYPE 2	LANGUAGE
	Installation and Operation Manual	

1.0 ABOUT THIS DOCUMENT

Please read this document carefully before mounting, starting, using and servicing **LS2** safety light curtains; it contains detailed instructions that must be followed with care.

In addition, pay special attention to Chapter 2 “**With reference to safety**”.

THIS DOCUMENT IS NOT IN ITS ORIGINAL LANGUAGE

1.1 Function of this document

This document provides the technical personnel of the manufacturer of a machine or the manager of the machine with the necessary instructions for safe mounting, electrical connection, starting and normal operation and maintenance of **LS2** safety light curtains.

The design and use of safety devices that utilize **LS2** safety light curtains require specific knowledge, but this is not entirely provided in this document.

The prescriptions of authorities and of the law must also be fundamentally respected for the installation and during normal operation of **LS2** safety light curtains.

1.2 Symbols used in this document



Warning to avoid danger!

A warning indicates real or potential hazards. Its task is to indicate procedures and behaviour that can avoid accidents. Read and follow these instructions carefully.



Indication

Indications that can help achieve better performance.



Emitter symbol

This symbol identifies devices that have the function of an Emitter.



Receiver symbol

This symbol identifies devices that have the function of a Receiver.



Body detection

This symbol marks devices designed to detect a body entering a protected area. It refers to multi-beam safety light grids with 2, 3 or 4 beams. These safety light grids are usually cost-effective and feature a long range, they enable creating protection for extensive areas and on more than one side, using diverter mirrors. These models are available in the LS2 series.



Limb or presence detection

This symbol marks devices designed to detect limbs entering a protected area or detect human presence in a protected area. For presence detection, with safety light curtains in a horizontal position, resolutions of between 50 and 116mm are to be used, the height off the ground is calculated in relation to these values. For this function the LS2 series features models with resolutions of 50 and 90mm.



Hand detection

This symbol marks devices designed to detect a hand entering a protected area. It refers to safety light curtains with a resolution less than or equal to 30mm and 40mm; these resolutions allow safety distances compatible with short loading and unloading times and a low level of operator fatigue.

 <p>M.D. Micro Detectors Strada S. Caterina, 235 41122 Modena Italy Tel. +39 059 420411 Fax +39 059 253973 www.microdetectors.com info@microdetectors.com</p>	LS2 SERIES SAFETY LIGHT CURTAIN TYPE 2	LANGUAGE
	Installation and Operation Manual	

2.0 WITH REFERENCE TO SAFETY



Warning!

The level of protection of the safety light curtain must be compatible with the dangerousness of the system to control, devices downstream from the must be compatible with the safety light curtain itself and with the required safety level.

- The machine must be able to be controlled electrically.
- It must be possible to stop the dangerous parts of the machine with an electric control achievable in a definite time and if necessary verified directly.



Warning!

The features of the safety light curtains must be chosen according to the size of the access area to the dangerous zone, the part of the human body subjected to the danger, the distance of the point of access from the dangerous point, the response time of the safety light curtains, the response time of the downstream devices and the time for stopping the dangerous movement.



Warning!

All the remaining hazardous conditions of the machine must be verified and suitable equipment must be used to neutralize them.

It must not be possible to reach the dangerous zone without going through the protection surface controlled by the safety light curtains.

For an operator must not be possible to remain between the surface of the protection controlled by the barrier and the danger zone without being detected.



Warning!

Check that the environmental conditions are compatible with the features of the safety light curtains. Check the effect of reflective surfaces to the side of the path of the light beams, in general respect the indicated safety distances.

Consider the effect of putting transparent panels or the like in between that can change the beam angle of the safety light curtains.

Prevent the safety light curtain's optical window from getting damaged or altered with scratches and opacifications.

Do not expose the Receiver to strong natural or artificial sources of light, including flashing stroboscopic sources.

Avoid exposing the Receiver directly to the projection of optical beams of other optical devices.

Check that the ambient temperature does not exceed the stated limits.

Consider the effect of smoke, vapours, liquids and powders that can alter the transparency of the air or foul the optical window.



Warning!

Periodically perform the procedures for checking the functionality of the safety light curtain.

2.1 Skilled personnel

Only qualified personnel are authorized to mount, start up, use and service the **LS2** safety light curtain.

A qualified person is one who:

- has adequate technical training
- has been educated by the person in charge of Machine Safety on its use and the current safety directives
- accesses the operating instructions.

2.2 Fields of use of the device

The **LS2** safety light curtains are Type-2 electro-sensitive protection equipment (ESPE) in accordance with IEC 61496-1 and IEC 61496-2. They can be employed in safety applications up to **Category 2** in conformity with EN ISO 13849, up to **SIL CL 2** in conformity with EN 62061 or up to **PL d** in conformity with EN 13849.

They meet the requirements of the Machinery Directive 2006/42/EC and are used to:

- protect the area of access to dangerous points.
- detect human presence in dangerous zones.
- protect the accesses to dangerous zones.



Use to standard

LS2 safety light curtains must be used only in accordance with Chapter 2.2 "Fields of use of the device". If the device is used for other purposes or if it is modified, even in the phase of mounting or installation, this invalidates all warranty rights with M. D. Micro Detectors.

 <p>M.D. Micro Detectors Strada S. Caterina, 235 41122 Modena Italy Tel. +39 059 420411 Fax +39 059 253973 www.microdetectors.com info@microdetectors.com</p>	LS2 SERIES SAFETY LIGHT CURTAIN TYPE 2	LANGUAGE
	Installation and Operation Manual	ENGLISH

2.3 General safety instructions and measures of protection

Safety instructions!

To ensure **LS2** safety light curtains are used to standard and in a safe manner it is necessary to observe the following points:

- For the installation and use of the **LS2** safety light curtain as for commissioning it and the repeated technical tests, national and international regulations apply, particularly:
 - Machinery directive 2006/42/EC
 - the Directive on work equipment operators 2009/104/EC
 - the accident prevention prescriptions and safety rules
 - other important safety prescriptions.
 - The manufacturers and operators of the machine on which the **LS2** safety light curtain is used must, in agreement with the relevant authority and under their own responsibility, apply all the current safety rules and prescriptions and are also in charge of their observance.
 - It is absolutely necessary to observe the guidelines on checking these operating instructions (see chapter 6 "**Commissioning**").
 - The checks must be carried out by qualified persons, that is by authorized and specially appointed persons, and they must be documented so as to be comprehensible at any moment.
 - The operating instructions contained in this manual must be set at the disposal of the operator of the machine used with **LS2** s.
- The machine operator must be educated by qualified personnel and urged to read the operating instructions.

2.4 Disposal

Dispose of unusable or unrepairable devices always in observance of current national prescriptions on the subject of waste disposal.

3.0 DESCRIPTION OF THE PRODUCT

3.1 Brief description

The **LS2** series curtains are multiple light beam safety devices, built in compliance with the IEC 61496-1 and 2 standards, are Type 2 and therefore applicable for the protection of the operators of systems or dangerous machines.

According to the requirements of the EN 61496-1 standard, a Type-2 safety light curtain must be able to carry out periodical testing on its internal circuits to detect the presence of any dangerous faults.

LS2 safety light curtains have a slim profile of **28x30mm**, the distance of 28mm refers to the front side, they have a rear groove for fastening, they are extremely reliable devices, the Receivers provide **two** protected static safety **PNP outputs**, so they are not subject to output contact wear or affected by strong vibration, they are able to detect internal faults, control external contacts and, in the event of a fault, ensure safe behaviour in any case. With a free area the level of the two outputs is enabled to be high (status ON, outgoing current), with an occupied area or in case of fault the level is low (status OFF).

The Emitters have a **Test** input, that can be used if it is necessary to control the devices downstream from the Receiver.

There are models with different resolutions (smaller diameter of the detectable object) dedicated to certain detection of hands, limbs and body; the different resolution for models of the same type enables choosing different safety distances.

Safety light curtains are available with resolutions of **30, 40, 50, 90 mm**, heights from **160 to 1810mm**, maximum ranges of **3, 4, 10, 12m**. Multi-beam safety light greed are available with **2, 3, 4 beams** dedicated to access control.

The **Base** and **standard** models can be used individually, the **Master, Slave** and **Final slave** models can be used in a chain of two or three elements, also with different types of optics; this enables creating complex applications in a simple cost-effective manner, for highly integrated protected zones even with different resolution or range requirements.

The **Base** models have only the automatic restart function without controlling the external contacts (EDM).

On the **standard** and **Master** models it is possible to combine all the functions by wiring as preferred: external contact control (EDM), automatic starting, manual starting.

All the models use **M12 connectors with 5 or 8 poles**, for the supply/output cables and the interconnection cables in a chain no shielding is required, the output cable can reach lengths of 100m, the interconnection cable 50m, these features also allow great operational flexibility.

The required operational voltage is **24V_{DC} ±20%**, the absorbed power is moderate, at most **3W** per pair; the maximum output current is **400mA**, suited to drive even power contactors directly; the restart interlock and EDM function, present on the **standard** and **Master** models, enable making versatile and integrated protection systems.

Normally, the degree of protection of the housing is **IP65+IP67**, suitable also for dusty environments or compatible with phenomena of condensation, except for the front surface that has strict optical requirements.

Models are available with **IP69K** protection that can be subjected to washing with jets of hot water up to 80°C and pressure up to 80 bar; with this level of protection models are also available with an integrated thermal auto-control system that moreover enables working at temperatures as low as -25°C and avoiding condensation on the optics.

 Micro Detectors Italian Sensors Technology	M.D. Micro Detectors Strada S. Caterina, 235 41122 Modena Italy Tel. +39 059 420411 Fax +39 059 253973 www.microdetectors.com info@microdetectors.com	LS2 SERIES SAFETY LIGHT CURTAIN TYPE 2	LANGUAGE
		Installation and Operation Manual	

3.2 Coding system

Tab.:1 gives the meaning of the codes of the available models.

The models are supplied in kit form composed of a pair (Emitter/Receiver), the single elements are available only to make up for a return.

For an overview of the main features of the models ready for delivery or available on request, see Tab.:2 and 3 in this chapter.

For a complete and detailed list of the actually coded models and their related features, see Chapter 9.

Directly contact M. D. Micro Detectors for any explanation.

LS2 SERIES		CONSTRUCTION OF MODEL CODES
POSITION	CODE	DESCRIPTION
1	LS2	Type-2 safety light curtains in housing of cross-section 28x30mm
2	R	Receiver (single element only available for the replacement of return goods)
	E	Emitter (single element only available for the replacement of return goods)
	ER	Emitter/Receiver pair
3	/	Separator
4	30, 40	Light curtain, resolution in mm; hand protection
	50, 90	Light curtain, resolution in mm; limb protection
	0A, 0B, 0C	Multiple beams light grid, number of beams 2, 3, 4; body protection Corresponding centre distance of the beams 500, 400, 300mm
5	-	Separator
6	015 to 180	Nominal height of controlled area in cm for light curtain models: 015, 030, 045, 060, 075, 090, 105, 120, 135, 150, 165, 180
	050, 080, 090	Centre distance of the end beams in cm for light grid models
7		Single element with selectable functions (Standard)
	B	Single element with only Base functions (Automatic restarting only) (For the Emitters the Standard and Base models are identical, the code of the pair is defined by the Receiver)
	M	Master element with selectable functions
	S	Intermediate Slave element
	F	Final Slave element
8		IP65 + IP67 Operating Temp. -10...55°C
	K	Models in transparent cylindrical housing, IP69K, suitable for applications in the food industry. Resistance to washing with water at 100 bar, 80 ° C Housing in PMMA, caps in POM C with silicone seals. Brackets in stainless steel AISI 316L. Operating temperature -10 ... 55 ° C.
	H	Models in transparent cylindrical casing, IP69K protection, thermostated, suitable for applications in the food industry. Resistance to washing with water at 100 bar, 80 ° C Housing in PMMA, POM C caps and silicone seals. Brackets in stainless steel AISI 316L. Operating temperature -10 ... 55 ° C.



Tab.:1; Chap.:3

 Micro Detectors Italian Sensors Technology	M.D. Micro Detectors Strada S. Caterina, 235 41122 Modena Italy Tel. +39 059 420411 Fax +39 059 253973 www.microdetectors.com info@microdetectors.com	LS2 SERIES SAFETY LIGHT CURTAIN TYPE 2	LANGUAGE
		Installation and Operation Manual	

3.3 Availability of models with IP65 + IP67 protection

Tab: 2 and 3 give the actually available models with reference to the optical parameters. The selection between the two "Low" and "High" ranges is performed via the cables in the Emitter. Models with an extended range are not available, which are instead available in the LS4 series.



See the tables of Chap.:9 for a complete list of the available models.

LS2 SERIES IP65+IP67		OPTICAL FEATURES				
APPLICATION		RESOLUTION (mm)	HEIGHT OF OPTICS (mm)	SELECTABLE RANGES		AVAILABLE MODELS
				Low (m)	High (m)	
	HAND PROTECTION	30	160 to 1810	0 to 4	0 to 12	LS2*/**.* Standard LS2*/**.*B Base ⁽¹⁾ LS2*/**.*M Master ^{(2) (3)} LS2*/**.*F Final Slave ⁽³⁾ LS2*/**.*S Intermediate Slave ^{(2) (3)}
	Curtain of beams	40 ⁽¹⁾	160 to 1510			
	LIMBS AND PRESENCE PROTECTION	50	160 to 1510			
	Curtain of beams	90	310 to 1510			
	ACCESS PROTECTION	No. of BEAMS	PITCH	0 to 4	0 to 12	LS2*/**.* Standard LS2*/**.*B Base ⁽¹⁾ LS2*/**.*M Master LS2*/**.*F Final Slave LS2*/**.*S Intermediate Slave
		2	500			
		3	400			
		4	300			

NOTES: The **Base [B]** models have limited functions (automatic restart only).
(1): For all models with resolution 40mm and Base models it is necessary to verify **availability**; **(2):** For the **Master** and **Intermediate Slave** models the optical height **160 is not available**; **(3):** for the **Master, Slave** and **Final Slave** models with resolution 90mm the optical height 1510 is not available.

Tab.:2; Chap.:3

3.4 Availability of models with IP69K protection

LS2 SERIES IP69K		OPTICAL FEATURES				
APPLICATION		RESOLUTION (mm)	HEIGHT OF OPTICS (mm)	SELECTABLE RANGES		AVAILABLE MODELS
				Low (m)	High (m)	
	HAND PROTECTION	30	160 to 1510	0 to 3	0 to 10	LS2*/30-***K standard, without heater (-10 to 55°C) LS2*/30-***H standard, with heater (-25 to 50°C) Models with standard range only
	Curtain of beams					
	ACCESS PROTECTION	No. of BEAMS	PITCH	0 to 3	0 to 10	LS2*/**.*K standard, without heater (-10 to 55°C) LS2*/**.*H standard, with heater (-25 to 50°C) Models with standard range only
		2	500			
		3	400			
		4	300			











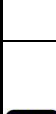

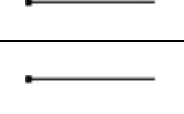



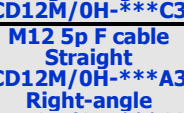

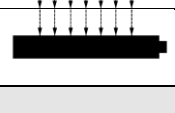
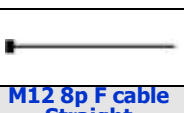

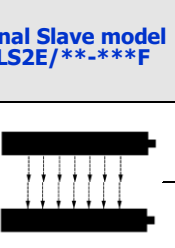
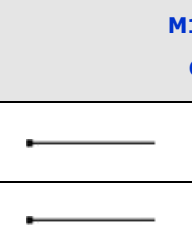
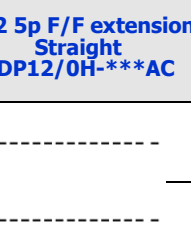
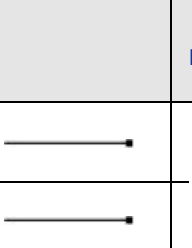
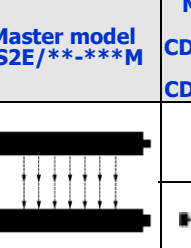
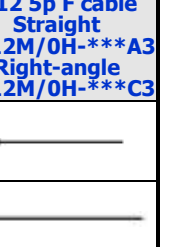

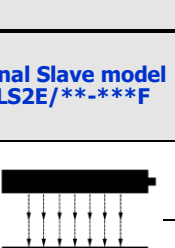

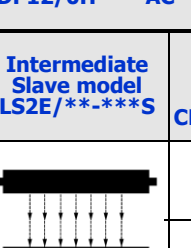
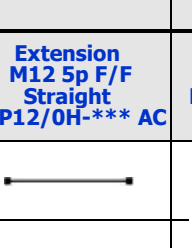
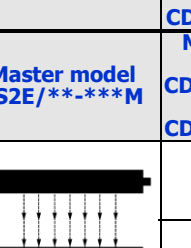
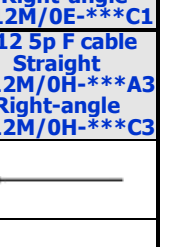
NOTES: All models are specified for applications in the food industry, IP69K, (washing at high pressure: 100 bar, 80 ° C)
 Only Standard models available (with complete functions: Automatic, Restart, EDM in all combinations)

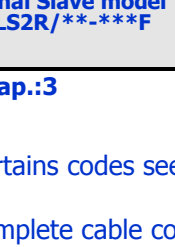
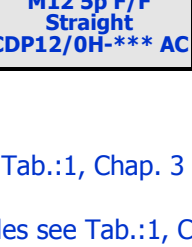
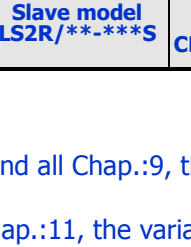
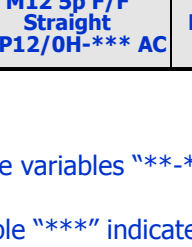
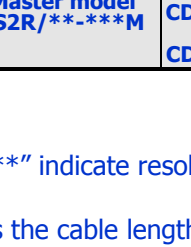
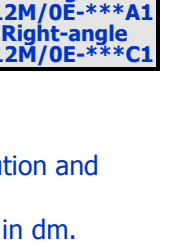
Tab.:3; Chap.:3

 Micro Detectors Italian Sensors Technology	M.D. Micro Detectors Strada S. Caterina, 235 41122 Modena Italy Tel. +39 059 420411 Fax +39 059 253973 www.microdetectors.com info@microdetectors.com	LS2 SERIES SAFETY LIGHT CURTAIN TYPE 2	LANGUAGE
		Installation and Operation Manual	ENGLISH

3.5 Possibility of interconnection of the available models

Tab: 4 shows the possible interconnections between models and their supply and extension cables.

← UPSTREAM devices		DOWNSTREAM devices →						
CONNECTOR		← BASE	HEAD →	CONNECTOR	← BASE	HEAD →	CONNECTOR	← BASE
LS2ER/**-***B							Base model LS2E/**-***B	M12 5p F cable Straight CD12M/0H-***A3 Right-angle CD12M/0H-***C3
								
LS2ER/**-***							Base model LS2R/**-***B	M12 5p F cable Straight CD12M/0H-***A3 Right-angle CD12M/0H-***C3
								
LS2ER/**-***							Standard model LS2E/**-***	M12 5p F cable Straight CD12M/0H-***A3 Right-angle CD12M/0H-***C3
								
LS2ER/**-***#		Final Slave model LS2E/**-***F	M12 5p F/F extension Straight CDP12/0H-***AC				Master model LS2E/**-***M	M12 5p F cable Straight CD12M/0H-***A3 Right-angle CD12M/0H-***C3
								
LS2ER/**-***#		Final Slave model LS2R/**-***F	M12 5p F/F extension Straight CDP12/0H-***AC				Master model LS2R/**-***M	M12 8p F cable Straight CD12M/0E-***A1 Right-angle CD12M/0E-***C1
								
LS2ER/**-***#		Final Slave model LS2E/**-***F	Extension M12 5p F/F Straight CDP12/0H-*** AC	Intermediate Slave model LS2E/**-***S	Extension M12 5p F/F Straight CDP12/0H-*** AC		Master model LS2E/**-***M	M12 5p F cable Straight CD12M/0H-***A3 Right-angle CD12M/0H-***C3
								
LS2ER/**-***#		Final Slave model LS2R/**-***F	Extension M12 5p F/F Straight CDP12/0H-*** AC	Intermediate Slave model LS2R/**-***S	Extension M12 5p F/F Straight CDP12/0H-*** AC		Master model LS2R/**-***M	M12 8p F cable Straight CD12M/0E-***A1 Right-angle CD12M/0E-***C1
								

Tab.:4; Chap.:3

NOTES:

For the curtains codes see Tab.:1, Chap. 3 and all Chap.:9, the variables “**-*” indicate resolution and height.

For the complete cable codes see Tab.:1, Chap.:11, the variable “***” indicates the cable length in dm.

 <p>M.D. Micro Detectors Strada S. Caterina, 235 41122 Modena Italy Tel. +39 059 420411 Fax +39 059 253973 www.microdetectors.com info@microdetectors.com</p>	LS2 SERIES SAFETY LIGHT CURTAIN TYPE 2	LANGUAGE
	Installation and Operation Manual	

4.0 INSTRUCTIONS FOR POSITIONING THE SAFETY LIGHT CURTAINS

4.1 Respecting the safety distance

A safety distance must be maintained between the protection surface composed of the beams of the optico-electronic safety light curtain and the point of danger.

This distance must ensure that, considering a maximum approach speed defined by the standard, the point of danger can only be reached when sufficient time has elapsed so that the dangerous state of the machine has ended.

The safety distance in accordance with EN ISO 13855 depends:

- in direct proportion on the total time for stopping the machine or system, which corresponds to the sum of the individual times of reaction of the whole safety chain (the individual response times are indicated in the technical documentation of the safety devices and of the machine itself or must be verified with specific measures).
- in direct proportion on the approach speed.
- in direct proportion on the resolution of the safety light curtain, or inversely to the number of beams for the unit of height.

If the machine is subject to a specific standard of type **C**, the indications of this standard must be followed.



Danger of failed recognition!

Particularly in access protection applications, people may stop in the danger area, but not in the optical beam between the Emitter and the Receiver, and their presence might not be recognized.

Make sure that dangerous states can only occur when there are no persons in the danger area.

Make sure that the system restart control is effected from a point providing full visibility of the danger area and that this control cannot be reached from within said area.



No protection function is secure if the safety distance is not correct!

It is indispensable to mount the safety light curtains at the correct safety distance to ensure the function of protection.



If there is a C-type standard for the application you are creating, follow its instructions!

The following instructions apply only to an industrial environment, that is to say where only adults of normal constitution are expected to be present.

 <p>M.D. Micro Detectors Strada S. Caterina, 235 41122 Modena Italy Tel. +39 059 420411 Fax +39 059 253973 www.microdetectors.com info@microdetectors.com</p>	LS2 SERIES SAFETY LIGHT CURTAIN TYPE 2	LANGUAGE
	Installation and Operation Manual	ENGLISH

4.2 How to calculate the safety distance S in conformity with EN ISO 13855 and EN ISO 13857

Here we give the general procedures for calculating the minimum safety distance S , these instructions must be followed if there is not a specific standard of type **C** for the machine to make safe.

Depending on the application it is necessary to use different calculation schemes.

In general the formula has this form:

$$S = K * T + C$$

Where...

S = [mm] Safety distance

K = [mm/s] Approach speed, a speed of **2000mm/s** is indicated for the upper limbs and **1600** for the lower limbs.

T = [s] Total stopping time: response time of the entire safety device + machine stopping time.

C = [mm] Safety distance supplement, to ensure that the dangerous zone cannot be reached by climbing over the beams or inserting limbs between the beams. It is provided by the standard, it takes on a fixed value or is calculated according to the optical features of the safety light curtain and its utilization in the application.



The reaction time of the safety light curtain alone is stated on the product label of the Receivers and in this document in the tables of Chap.:9.

In the case of a chain connection the reaction time of the safety light curtains corresponds to the sum of all the individual times of the Receiver elements in the chain.

The standard considers different methods of approach:

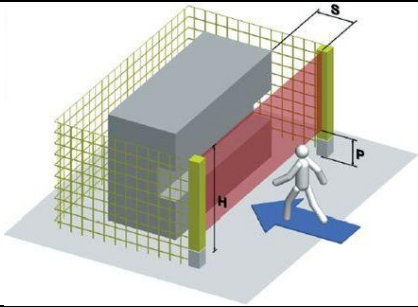
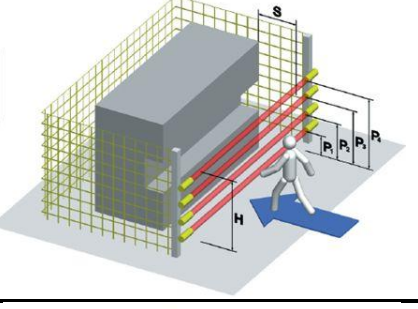
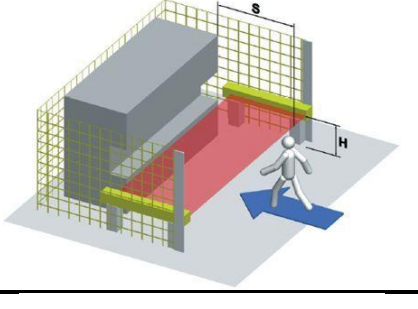
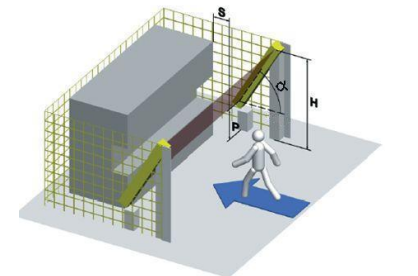
	<p style="text-align: center;">1) PERPENDICULAR APPROACH</p> <p style="text-align: center;">Safety light curtain in vertical position. Angle between safety light curtain and surface of $90^\circ \pm 5^\circ$</p>
	<p style="text-align: center;">2) PERPENDICULAR APPROACH</p> <p style="text-align: center;">Safety light grid in vertical position. Angle between safety light curtain and surface of $90^\circ \pm 5^\circ$</p>
	<p style="text-align: center;">3) HORIZONTAL APPROACH</p> <p style="text-align: center;">Safety light curtain in horizontal position. Angle between safety light curtain and surface of $0^\circ \pm 5^\circ$</p>
	<p style="text-align: center;">4) OBLIQUE APPROACH</p> <p style="text-align: center;">Safety light curtain in angled position. Two cases are considered for different angle values α</p> <p style="text-align: center;">With $\alpha \geq 30^\circ$ we have the perpendicular approach With $\alpha < 30^\circ$ we have the horizontal approach</p>

Tab.:1; Chap.:4

• **Calculate S with the following procedure for applications of protection with safety light curtains over which it is possible to climb.**

If a safety light curtain is installed without any supplementary mechanical protection on the top, and therefore it is possible to enter the protected area from above, it is necessary to define the safety distance considering two methods:

- Access from above.
- Access through the beams.
- Access from below, not considered now, can be excluded if the lowest beam has a maximum height of 200mm from the surface, or by installing mechanical protection.

The safety distance, considering access from above, must be such as not to allow reaching the danger area; this safety distance is obtained from **Tab.:2 of ISO 13855**, here Tab.:3; Chap.:4

The safety distance, considering access between the beams, is obtained from the procedures indicated below that envisage access only through the beams.

The safety distance to choose will be the greater one of the two.

To have indications of the dimensions of any mechanical protection to superimpose on the safety light curtain or only mechanical protection not closed on the top part, please refer to standard **EN ISO 13857**.

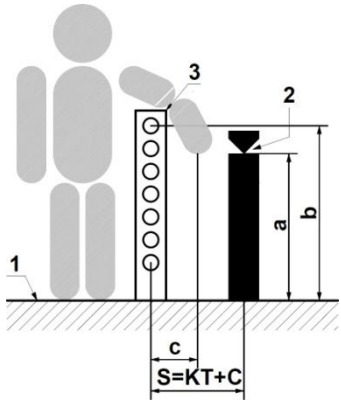
	<p>1) Reference surface</p> <p>2) Dangerous point or danger area</p> <p>3) Photo-electric safety light curtain</p> <p>a) Height above the surface of the dangerous point or of the higher point of the danger area</p> <p>b) Height above the surface of the top of the optical window of the safety light curtain.</p> <p>c) Minimum safety distance so as not to reach the danger area from above is obtained from Tab.:2 of ISO 13855 here Tab.:3; Chap.:4</p> <p>C) Length of the path of the limb through the beams, from the level of the optics until the two optics are completely darkened (resolution) Route of the limb through the safety light curtain during the total time</p> <p>KT) T of the response to stopping, considering a specific approach speed K</p> <p>S) Minimum safety distance between the safety light curtain and danger area calculated considering access through the beams, see the following cases</p>
--	--

Tab.:2; Chap.:4

Tab.:2 from ISO 13855/ EN999

		[c] MINIMUM DISTANCE TO IMPLEMENT BETWEEN THE CURTAIN AND DANGER AREA											
[a] HEIGHT OF THE DANGER AREA	2600	0	0	0	0	0	0	0	0	0	0	0	0
	2500	400	400	350	300	300	300	300	300	250	150	100	0
	2400	550	550	550	500	450	450	400	400	300	250	100	0
	2200	800	750	750	700	650	650	600	550	400	250	0	0
	2000	950	950	850	850	800	750	700	550	400	0	0	0
	1800	1100	1100	950	950	850	800	750	550	0	0	0	0
	1600	1150	1150	1100	1000	900	800	750	450	0	0	0	0
	1400	1200	1200	1100	1000	900	850	650	0	0	0	0	0
	1200	1200	1200	1100	1000	850	800	0	0	0	0	0	0
	1000	1200	1150	1050	950	750	700	0	0	0	0	0	0
	800	1150	1050	950	800	500	450	0	0	0	0	0	0
	600	1050	950	750	550	0	0	0	0	0	0	0	0
	400	900	700	0	0	0	0	0	0	0	0	0	0
	200	600	0	0	0	0	0	0	0	0	0	0	0
0	0	0	0	0	0	0	0	0	0	0	0	0	
		900	1000	1100	1200	1300	1400	1600	1800	2000	2200	2400	2600
		[b] HEIGHT OF THE TOP EDGE OF THE OPTICAL WINDOW OF THE CURTAIN											

Tab.:3; Chap.:4

	M.D. Micro Detectors Strada S. Caterina, 235 41122 Modena Italy Tel. +39 059 420411 Fax +39 059 253973 www.microdetectors.com info@microdetectors.com	LS2 SERIES SAFETY LIGHT CURTAIN TYPE 2	LANGUAGE
		Installation and Operation Manual	ENGLISH

- Calculate S with the following procedure for finger or hand protection applications, with vertical curtains (90° ±5°) having the stated resolution D.

	Resolution	Formula	Description
	D ≤ 40 (mm)	$S \text{ (mm)} = 2000 * T + 8x(D-14)$	From finger protection to hand protection

If there is a value $S < 100\text{mm}$, use $S = 100\text{mm}$.

If there is a value $S > 500\text{mm}$, it is permissible to calculate again using the approach speed **1600 m/s**:

$S \text{ (mm)} = 1600 * T + 8x(D-14)$

If from this new calculation there is a value $S < 500\text{mm}$, use $S = 500\text{mm}$.

If there are any remaining uncontrolled access areas, they must have an access width of $\leq 75\text{mm}$ to prevent limbs from reaching the danger zone, otherwise it is necessary to add more protection.

- Calculate S with the following procedure for upper limb protection applications, with vertical curtains (90° ±5°) having the stated resolution D.

	Resolution	Formula	Description
	$40 < D \text{ (mm)} \leq 70$	$S \text{ (mm)} = 1600 * T + 850$	Limb Protection

The height off the ground of the lowest beam must be $P \leq 300\text{mm}$.

The height off the ground of the highest beam must be $H \geq 900\text{mm}$.

- Calculate S with the following procedure and use the beam height indicated off the reference surface for access protection applications, with vertical curtains (90° ±5°) having stated resolution D.

	Resolution	Formula	Description
	D > 70 (mm)	$S \text{ (mm)} = 1600 * T + 850$	Access protection

For curtains in a row, the lowest beam must be no higher than **300mm** and the higher one must be no lower than **1200mm**.

When using curtains with multiple beams, it is necessary to observe the heights of the beams off the reference surface indicated in the following table:

No. of Beams	P1 (mm)	P2 (mm)	P3 (mm)	P4 (mm)
2	400	900		
3	300	700	1100	
4	300	600	900	1200

Tab.:4; Chap.:4

- Use S and the beam height off the roller conveyor as stated for curtains with two or three beams in protection applications for passageways for palletizers and depalletizers (machines subject to the C-type product standard: EN 415-4).

No. of Beams	P1 (mm)	P2 (mm)	P3 (mm)	S (mm)
2	400	900		1200
3	400	800	1200	900

Tab.:5; Chap.:4

- Calculate S with the following procedure for body protection applications, with curtains parallel to the direction of approach (0° ±5°) having height H off the surface and resolution D.

	Resolution	Formula	Description
	$116 \geq D \geq 50 \text{ (mm)}$	$S \text{ (mm)} = 1600 * T + C$ $C \text{ (mm)} = (1200 - 0,4 * H); C \geq 850$ $D \text{ (mm)} \leq (H/15) + 50$ $15 * (D - 50) \leq H \text{ (mm)} \leq 1000$	Access and presence protection

If C takes on values below **850 (mm)**, use $C = 850$.

The height of the curtain off the ground must be $H \leq 1000 \text{ (mm)}$.

For $H > 300\text{mm}$ install supplementary protection to avoid the risk of access from beneath.

It is possible to use smaller resolutions than **50mm**, but this brings no advantage (the minimum distance off the ground is null even with a resolution of **50mm**).

 Micro Detectors Italian Sensors Technology	M.D. Micro Detectors Strada S. Caterina, 235 41122 Modena Italy Tel. +39 059 420411 Fax +39 059 253973 www.microdetectors.com info@microdetectors.com	LS2 SERIES SAFETY LIGHT CURTAIN TYPE 2	LANGUAGE
		Installation and Operation Manual	

5.0 MINIMUM DISTANCE FROM REFLECTING SURFACES

The optical beams of the Emitter, having a beam angle that is not null, can partly be diverted by reflective surfaces located near to the curtains. This may mean that a break in the direct path of the optical beam is not detected, which is why all reflective surfaces and reflective objects (in any position they may have with respect to the controlled area, above, under, inside or outside) must respect a minimum distance from the direct path of the beams of the safety light curtain.



Indication

It is likewise important to respect the minimum distance between the Emitter and Receiver indicated by the manufacturer, in some cases the minimum distance may be greater than zero, especially for long-range models.

At smaller minimum distances than the ones stated, the beam angle may have an unpredictable breadth and so the safety distance may not be definable with certainty.

When using diverter mirrors, consider that the minimum distance from reflective surfaces must be respected for all the rectilinear segments of the beams, considering the sides both inside and outside the protected zone.

A reflective surface is any shiny surface, even a black one.

Any damage or opacification of the optics or inclusion of slabs of transparent or, even worse, semitransparent material on the optical path can produce an increase in the beam angle.

Checking the capacity of detection with the test rod, performed in the intermediate and at the ends of the controlled area, is an effective procedure to exclude the presence of dangerous reflections, see also Chap.:13.4.

5.1 How to calculate the minimum distance from reflective surfaces

The safety light curtains **LS2** respect the maximum beam angle defined by IEC / EN 61496-2 for **Type 2** ($\alpha/2 = \pm 5^\circ$), or less.

The safety distance **D** is calculated considering the entire beam angle $\alpha = 10^\circ$ and the safety light curtains reciprocally orientated towards the reflective surface by an angle α , in this way we consider the case of alignment at the limit of reciprocal visibility between the Emitter and Receiver, but which is more dangerous due to the effects of the reflection.

The safety distance **D** to take $P \geq 3m$ is calculated as follows:

$$D = \tan(10^\circ) * P/2 = 0.1763 * P/2$$

For ranges less than 3m the value calculated at **3m** applies:

$$D = 0.1763 * 1.5 = 0.264m$$

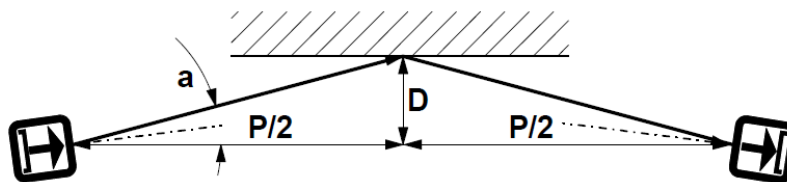

Fig.:1; Chap.:5; this figure shows the worst borderline case that can occur: safety light curtains not perfectly aligned, but tilted by an angle $\alpha/2$ towards a reflective surface.

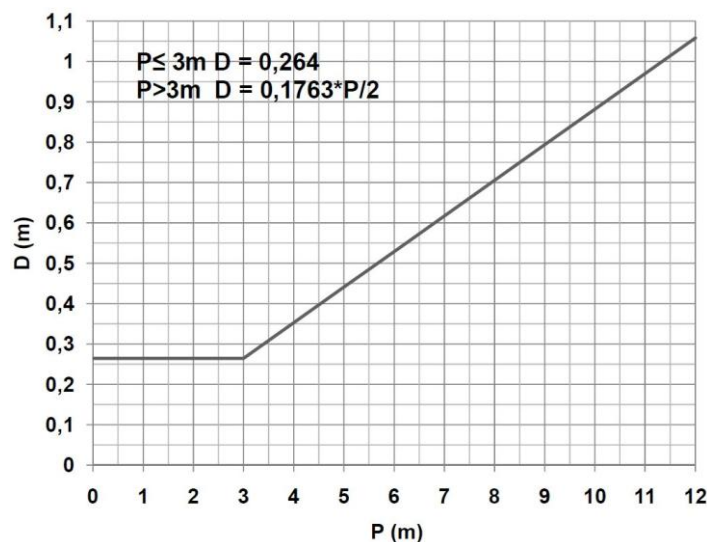



Fig.:2; Chap.:5; minimum distance "D" to maintain for the reflective surfaces in relation to the range "P".

 <p>M.D. Micro Detectors Strada S. Caterina, 235 41122 Modena Italy Tel. +39 059 420411 Fax +39 059 253973 www.microdetectors.com info@microdetectors.com</p>	LS2 SERIES SAFETY LIGHT CURTAIN TYPE 2	LANGUAGE
	Installation and Operation Manual	

6.0 COMMISSIONING

6.1 Mechanical mounting

This device is suited to work in protected environments, not outdoors.

It is extremely important to secure the safety light curtains to a rigid structure, not subject to deformation or strong vibration.

Choose the position of the Receiver so as not to subject it to strong sources of natural or artificial light or to luminous interference by other sensors.

Mount the Emitter and Receiver facing each other, at the same height off the reference surface and with the same orientation (refer to the BASE side that is the display side), the reciprocal distance must be within the field of the specification. To secure the safety light curtains to a support use the specific inserts to apply to the rear groove and the brackets normally provided.

If there is vibration in the application, but still compatible with the optical alignment, use the damping supports available as accessories.

In this phase classic tools such as a plumb line and/or a spirit level may be useful.

To facilitate the first phase of alignment, it is possible to use the specific LASER **STL 01 S** accessory for safety light curtains with a profile of 28x30mm.

Temporarily block the Emitter and Receiver so they are aligned with and parallel to each other.



Danger!

To perform the next steps it is necessary to power the Emitter and Receiver, make sure that during this phase the machine's movements are blocked irrespective of the state that the Receiver will take on; an effective manner to obtain this is to physically cut off the supply to the actuators by permanently disconnecting their supply cables.

6.2 Alignment

1) When switching on the LED 1 of the Emitter will be RED for the duration of the power-on, if afterwards the LED makes two short GREEN flashes the High range function is active, if the LED makes 2/3 RED flashes, the TEST is probably open and there is no emission (jumper TEST to proceed), if the LED is illuminated GREEN it means that the Emitter is working. In case of difficulty with alignment it is advisable to temporarily activate the High range function, if it is not already enabled, so as to facilitate it. Refer to Chap.: 6.3 to verify the Emitter and Receiver configuration mode and to Chap.:8 for the meaning of the indications.

2) If it is possible to choose or temporarily change the configuration of the Receiver, it is advised to use the "Automatic Restart without EDM" mode, that is able to clearly signal the state of LIGHT and outputs ON lighting up LED 3, that in this case will be GREEN; if the Receiver has been configured differently (restart interlock with or without EDM), observe instead LED 2, that in this case will be YELLOW, indicating the state of LIGHT, but outputs OFF; YELLOW LED 2 will be blinking in case of MASTER on LIGHT connected to slaves on DARK.

To simplify any Receiver will be on light if LED 3 is GREEN or LED 2 is YELLOW on steady or blinking.

3) Now try adjusting the Receiver around the original position and define a zone in which the Receiver is in the LIGHT. *More careful alignment than as obtained normally could be ensured by temporarily darkening the optics of the Receiver with opaque adhesive tape precisely covering half of the optical window and then seeking the condition of light under these conditions; on obtaining the condition of LIGHT, on removing the tape the signal will be at least with margin 2.* Now check that with moderate mechanical stresses applied to the safety light curtain it remains in the LIGHT. Now proceed with step 5).

4) If you are not able to bring the Receiver into the light or to ensure an adequate level of margin, correct the position of the Emitter and try to align the Receiver again, step 3).

5) Again temporarily lock the Receiver in the intermediate of the found zone and check it has an acceptable arrangement. If it is acceptable proceed with step 6), if it is not acceptable correct the alignment of the Emitter accordingly and realign the Receiver, step 3).

6) After alignment, permanently lock the safety light curtains and restore all the required conditions for the application, including the electric connections.

7) Have complete functional testing carried out on the safety light curtain, including a resolution test and checking for the presence of reflective surfaces, using a test rod, of the same diameter as the rated resolution.

8) Make sure that during normal use no unfavourable conditions arise around, such as:

- presence of other Emitters or other bright or modulated sources of light able to hit the Receiver,
- presence or movement of reflective objects near the area,
- transparent or semi-transparent materials inserted in the path of the beams,
- systematic presence of dust or spray of liquids able to foul the surface of the optics.



Indication

Correct optical alignment with good excess gain enables avoiding instability in the behaviour of the safety light curtain, reducing optical interference, reflections from shiny surfaces and in general ensuring greater safety.



Danger!

Remember to restore the wiring and check the required methods of operation of the application again.

 <p>M.D. Micro Detectors Strada S. Caterina, 235 41122 Modena Italy Tel. +39 059 420411 Fax +39 059 253973 www.microdetectors.com info@microdetectors.com</p>	LS2 SERIES SAFETY LIGHT CURTAIN TYPE 2		LANGUAGE
	Installation and Operation Manual		ENGLISH

6.3 Electrical installation.

Before proceeding carefully read the data of Tab.:1; Chap.:7 in the sections: Supply, Outputs and Connections.

See Tab.: 1-4 in this chapter to make the required connections for the supply, load and configuration for the connectors. Preferably use prewired connectors; for the Master/Slave connections use only extensions.

Use PELV power supplies, in accordance with Chap.6.4. of EN 60204-1.

If using a non-stabilized power supply, the transformer must have double insulation and adequate power, the secondary winding must be 18V, use a bridge rectifier, use a filtering capacitor with a minimum value of 2200µF for absorptions up to 1A, for higher absorptions add 2200µF for every extra Ampere.

Connect the supply cables directly to the source and not downstream of other power or highly inductive devices.

Run the cables of the safety light curtains in dedicated raceways or, where only signals run; do not use raceways that carry power cables.

Make sure the functional earth cable (FE) is connected directly to the general ground terminal.

Before inserting the connector, check that the mains voltage and the supply voltage are within the required limits, apply the connector and check again that the supply voltage has a correct nominal value and remains within the limits defined in all the working conditions, check the limits in the two extreme conditions of minimum and maximum absorption of all of the devices connected to the same power supply, especially if this is not a stabilized power supply.

In the following tables the colours of the cables and LEDs are indicated with the abbreviations defined in IEC 60707 in English

BK	BN	RD	YE	OG	GN	BU	GY	WH	PK	VT
Black	Brown	Red	Yellow	Orange	Green	Blue	Grey	White	Pink	Violet

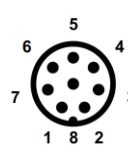
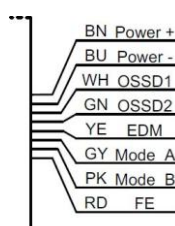
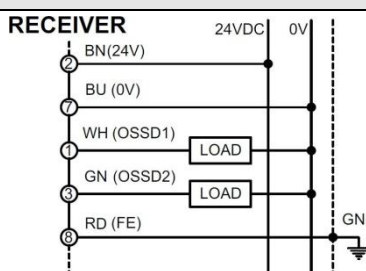
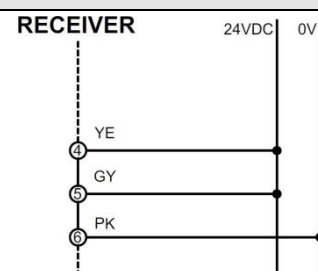
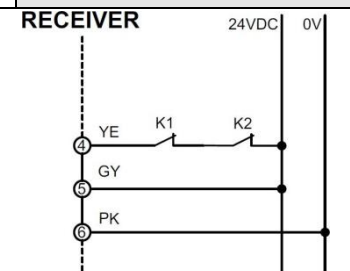
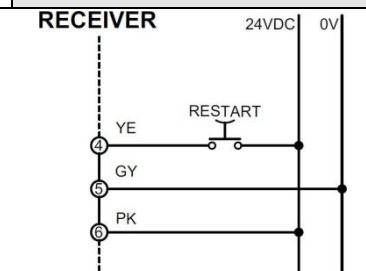
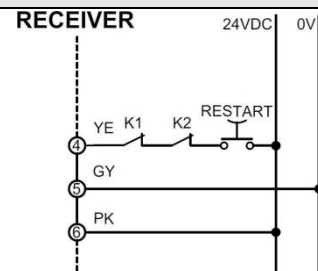
SERIE LS2 RECEIVER				CONNECTOR AND CABLE EXIT WITH EIGHT POLES				
				Standard and Master models: LS2R/**-***; LS2R/**-***M (connector exit) Standard models, IP69K: LS2R/**-***K (cable exit)				
M12, 8 pole Male connector	8-wire cable Only K models	Power supply and loads		1 Automatic restart without EDM				
								
2 Automatic restart with EDM		3 Manual restart without EDM		4 Manual restart with EDM				
								
Pin	Color	Signal	Type	Description	CONFIGURATION LOGIC			
					Pin 4	Pin 5	Pin 6	Function
1	WH	OSSD1	OUT	First safety static output (PNP)	24V _{DC}	24V _{DC}	0V	AUTO
2	BN	24V _{DC}	POWER	Power supply input	K1+K2 +24V _{DC}	24V _{DC}	0V	AUTO + EDM
3	GN	OSSD2	OUT	Second safety static output (PNP)	Restart +24V _{DC}	0V	24V _{DC}	MANUAL
4	YE	EDM	IN	Connection to Restart and/or external control contacts (EDM).	K1+K2+Restart +24V _{DC}	0V	24V _{DC}	MANUAL + EDM
5	GY	Mode_A	IN					
6	PK	Mode_B	IN	Selection of the Start/Restart/EDM mode				
7	BU	0V	POWER	Supply voltage reference				
8	RD	FE	GND	Functional earth				
NOTE: On these Standard and Master models it is possible to choose the operating modes by changing the wiring. By using the EDM function it is possible to extend the safety control to the contactors controlled downstream, that must be the type with guided contacts and approved for safety applications. With this model of curtain you can use the relay module SB300, but the EDM input must be connected.								

Tab.:1; Chap.:6

SERIES LS2 RECEIVER		CONNECTOR EXIT WITH FIVE POLES																															
Base models: LS2R/**-***B																																	
M12, 5 pole male	Diagram	Wiring																															
<table border="1" style="width:100%; border-collapse: collapse; font-size: 8px;"> <thead> <tr> <th>Pin</th> <th>Colour</th> <th>Signal</th> <th>Type</th> <th>Description</th> </tr> </thead> <tbody> <tr> <td>1</td> <td>BN</td> <td>24V_{DC}</td> <td>POWER</td> <td>Power supply input</td> </tr> <tr> <td>2</td> <td>WH</td> <td>OSSD1</td> <td>OUT</td> <td>First safety static output (PNP)</td> </tr> <tr> <td>3</td> <td>BU</td> <td>0V</td> <td>POWER</td> <td>Power supply reference</td> </tr> <tr> <td>4</td> <td>BK</td> <td>OSSD2</td> <td>OUT</td> <td>Second safety static output (PNP)</td> </tr> <tr> <td>5</td> <td>GY</td> <td>FE</td> <td>GND</td> <td>Functional earth</td> </tr> </tbody> </table>	Pin	Colour	Signal	Type	Description	1	BN	24V _{DC}	POWER	Power supply input	2	WH	OSSD1	OUT	First safety static output (PNP)	3	BU	0V	POWER	Power supply reference	4	BK	OSSD2	OUT	Second safety static output (PNP)	5	GY	FE	GND	Functional earth			
Pin	Colour	Signal	Type	Description																													
1	BN	24V _{DC}	POWER	Power supply input																													
2	WH	OSSD1	OUT	First safety static output (PNP)																													
3	BU	0V	POWER	Power supply reference																													
4	BK	OSSD2	OUT	Second safety static output (PNP)																													
5	GY	FE	GND	Functional earth																													
NOTE: These Base models with automatic restart do not have the EDM function, the device downstream must therefore be able to control its own safety integrity independently. With this model of curtain you can not use the relay module SB300, because the EDM input is not available.																																	

Tab.:2; Chap.:6

SERIES LS2 RECEIVER		CABLE EXIT WITH TEN POLES																																																																												
Models IP69K, thermostated: LS2R/**-***H																																																																														
10-wire cable	Power supply and loads	Heater power	1 Automatic restart without EDM																																																																											
2 Automatic restart with EDM	3 Manual restart without EDM	4 Manual restart with EDM																																																																												
<table border="1" style="width:100%; border-collapse: collapse; font-size: 8px;"> <thead> <tr> <th>Colour</th> <th>Signal</th> <th>Type</th> <th>Description</th> </tr> </thead> <tbody> <tr> <td>BN</td> <td>24V_{DC}</td> <td>POWER</td> <td>Power supply input</td> </tr> <tr> <td>BU</td> <td>0V</td> <td>POWER</td> <td>Supply voltage reference</td> </tr> <tr> <td>WH</td> <td>OSSD1</td> <td>OUT</td> <td>First safety static output (PNP)</td> </tr> <tr> <td>GN</td> <td>OSSD2</td> <td>OUT</td> <td>Second safety static output (PNP)</td> </tr> <tr> <td>YE</td> <td>EDM</td> <td>IN</td> <td>Connection to Restart and/or external control contacts (EDM).</td> </tr> <tr> <td>GY</td> <td>Mode A</td> <td>IN</td> <td rowspan="2">Selection of the Start/Restart/EDM mode</td> </tr> <tr> <td>PK</td> <td>Mode B</td> <td>IN</td> </tr> <tr> <td>BK</td> <td>Heater 0</td> <td>POWER</td> <td>Heater supply common</td> </tr> <tr> <td>VT</td> <td>Heater P</td> <td>POWER</td> <td>Heater supply 24V DC o AC</td> </tr> <tr> <td>RD</td> <td>FE</td> <td>GND</td> <td>Functional earth</td> </tr> </tbody> </table>	Colour	Signal	Type	Description	BN	24V _{DC}	POWER	Power supply input	BU	0V	POWER	Supply voltage reference	WH	OSSD1	OUT	First safety static output (PNP)	GN	OSSD2	OUT	Second safety static output (PNP)	YE	EDM	IN	Connection to Restart and/or external control contacts (EDM).	GY	Mode A	IN	Selection of the Start/Restart/EDM mode	PK	Mode B	IN	BK	Heater 0	POWER	Heater supply common	VT	Heater P	POWER	Heater supply 24V DC o AC	RD	FE	GND	Functional earth	<table border="1" style="width:100%; border-collapse: collapse; font-size: 8px;"> <thead> <tr> <th colspan="4">CONFIGURATION LOGIC</th> </tr> <tr> <th>YE</th> <th>GY</th> <th>PK</th> <th>Function</th> </tr> </thead> <tbody> <tr> <td>24V_{DC}</td> <td>24V_{DC}</td> <td>0V</td> <td>AUTO</td> </tr> <tr> <td>K1+K2 +24V_{DC}</td> <td>24V_{DC}</td> <td>0V</td> <td>AUTO + EDM</td> </tr> <tr> <td>Restart +24V_{DC}</td> <td>0V</td> <td>24V_{DC}</td> <td>MANUAL</td> </tr> <tr> <td>K1+K2 +Restart +24V_{DC}</td> <td>0V</td> <td>24V_{DC}</td> <td>MANUAL + EDM</td> </tr> <tr> <td>X</td> <td>0V</td> <td>0V</td> <td>NOT ALLOWED</td> </tr> <tr> <td>X</td> <td>24V_{DC}</td> <td>24V_{DC}</td> <td>NOT ALLOWED</td> </tr> </tbody> </table>			CONFIGURATION LOGIC				YE	GY	PK	Function	24V _{DC}	24V _{DC}	0V	AUTO	K1+K2 +24V _{DC}	24V _{DC}	0V	AUTO + EDM	Restart +24V _{DC}	0V	24V _{DC}	MANUAL	K1+K2 +Restart +24V _{DC}	0V	24V _{DC}	MANUAL + EDM	X	0V	0V	NOT ALLOWED	X	24V _{DC}	24V _{DC}	NOT ALLOWED
Colour	Signal	Type	Description																																																																											
BN	24V _{DC}	POWER	Power supply input																																																																											
BU	0V	POWER	Supply voltage reference																																																																											
WH	OSSD1	OUT	First safety static output (PNP)																																																																											
GN	OSSD2	OUT	Second safety static output (PNP)																																																																											
YE	EDM	IN	Connection to Restart and/or external control contacts (EDM).																																																																											
GY	Mode A	IN	Selection of the Start/Restart/EDM mode																																																																											
PK	Mode B	IN																																																																												
BK	Heater 0	POWER	Heater supply common																																																																											
VT	Heater P	POWER	Heater supply 24V DC o AC																																																																											
RD	FE	GND	Functional earth																																																																											
CONFIGURATION LOGIC																																																																														
YE	GY	PK	Function																																																																											
24V _{DC}	24V _{DC}	0V	AUTO																																																																											
K1+K2 +24V _{DC}	24V _{DC}	0V	AUTO + EDM																																																																											
Restart +24V _{DC}	0V	24V _{DC}	MANUAL																																																																											
K1+K2 +Restart +24V _{DC}	0V	24V _{DC}	MANUAL + EDM																																																																											
X	0V	0V	NOT ALLOWED																																																																											
X	24V _{DC}	24V _{DC}	NOT ALLOWED																																																																											
NOTA: On these Standard models it is possible to choose the operating modes by changing the wiring. By using the EDM function it is possible to extend the safety control to the contactors controlled downstream, that must be the type with guided contacts and approved for safety applications. The supply voltage of the thermostated heater can be indifferently 24VDC or 24VAC. With this model of curtain you can use the relay module SB300, but the EDM input must be connected.																																																																														

Tab.:3; Cap.:6

SERIE LS2 EMITTER		CONNECTOR AND CABLE EXIT WITH FIVE POLES																		
		Standard and Master models: LS2E/**_***; LS2E/**_***M (connector output) Models IP69K: LS2E/**_***K (cable output) For the emitters the Base and Standard models have identical functions.																		
M12, 5 pole Male connector	5-pole cable Only models K	Wiring for high range	Wiring for low range																	
Pin	Colour	Signal	Type	Description	CONFIGURATION LOGIC															
1	BN	24V _{DC}	POWER	Power supply input	<table border="1" style="width:100%; border-collapse: collapse;"> <thead> <tr> <th>WH</th> <th>BK</th> <th>Function</th> </tr> </thead> <tbody> <tr> <td>LO</td> <td>LO</td> <td>Test</td> </tr> <tr> <td>LO</td> <td>HI</td> <td>High range</td> </tr> <tr> <td>HI</td> <td>LO</td> <td>Low range</td> </tr> <tr> <td>HI</td> <td>HI</td> <td>Not admitted</td> </tr> </tbody> </table> <p>Levels: LO = <5V or open; HI = 11 to 30V</p>	WH	BK	Function	LO	LO	Test	LO	HI	High range	HI	LO	Low range	HI	HI	Not admitted
WH	BK	Function																		
LO	LO	Test																		
LO	HI	High range																		
HI	LO	Low range																		
HI	HI	Not admitted																		
2	WH	Range L/Test	IN	Range or Test selection input																
3	BU	0V	POWER	Supply voltage reference																
4	BK	Range H/Test	IN	Range or Test selection input																
5	GY	FE	GND	Functional earth																
NOTE: The Test contact is necessary only if the safety chain of the receiver downstream must be periodically checked. If the Test is not necessary (the safety light curtain has already been tested independently) replace the contact with direct wiring at +24V _{DC} .																				

Tab.:4; Chap.:6

SERIE LS2 EMITTER		CABLE EXIT WITH EIGHT POLES																	
		Models IP69K, thermostated: LS2E/**_***#H																	
8-pole cable Only models H	Wiring for high range	Wiring for low range																	
Colour	Signal	Type	Description	CONFIGURATION LOGIC															
BN	24V _{DC}	POWER	Power supply input	<table border="1" style="width:100%; border-collapse: collapse;"> <thead> <tr> <th>WH</th> <th>BK</th> <th>Function</th> </tr> </thead> <tbody> <tr> <td>LO</td> <td>LO</td> <td>Test</td> </tr> <tr> <td>LO</td> <td>HI</td> <td>High range</td> </tr> <tr> <td>HI</td> <td>LO</td> <td>Low range</td> </tr> <tr> <td>HI</td> <td>HI</td> <td>Not admitted</td> </tr> </tbody> </table> <p>Levels: LO = <5V or open; HI = 11 to 30V</p>	WH	BK	Function	LO	LO	Test	LO	HI	High range	HI	LO	Low range	HI	HI	Not admitted
WH	BK	Function																	
LO	LO	Test																	
LO	HI	High range																	
HI	LO	Low range																	
HI	HI	Not admitted																	
WH	Range L/Test	IN	Range or Test selection input																
BU	0V	POWER	Supply voltage reference																
GN	Range H/Test	IN	Range or Test selection input																
PK	None	N.C.	Not connected																
YE	Heater 0	POWER	Heater supply common																
RD	Heater P	POWER	Heater supply 24V DC o AC																
GY	FE	GND	Functional earth																
NOTA: The Test contact is necessary only if the safety chain of the receiver downstream must be periodically checked. If the Test is not necessary (the safety light curtain has already been tested independently) replace the contact with direct wiring at +24V _{DC} . The supply voltage of the thermostated heater can be indifferently 24VDC or 24VAC. The PK cable is not connected internally.																			

Tab.:5; Chap.:6

 Micro Detectors Italian Sensors Technology	M.D. Micro Detectors Strada S. Caterina, 235 41122 Modena Italy Tel. +39 059 420411 Fax +39 059 253973 www.microdetectors.com info@microdetectors.com	LS2 SERIES SAFETY LIGHT CURTAIN TYPE 2	LANGUAGE
		Installation and Operation Manual	

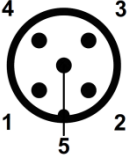
LS2 SERIES RECEIVER AND EMITTER		CONNECTORS FOR INTERCONNECTION OF MASTER/SLAVE/FINAL WITH FIVE POLES LS2*/**-***M; LS2*/**-***S; LS2*/**-***F		
M12, 5 pole male		Head connector Master/Slave		Base connector Slave/Final
		EMITTER/RECEIVER 		EMITTER/RECEIVER
Pin	Colour	Signal	Type	Description
1	BN	24V _{DC}	POWER	Power supply (supply line for the upstream device)
2	WH	Line 1	IN/OUT	Communication line 1
3	BU	0V	POWER	Power supply reference (supply line for the upstream device)
4	BK	Line 2	IN/OUT	Communication line 2
5	GY	FE	GND	Functional earth
NOTE: Preferably use Female/Female pre-wired extension cables (it is not permitted to access the connection lines).				

Tab.:6; Chap.:6

 Micro Detectors Italian Sensors Technology	M.D. Micro Detectors Strada S. Caterina, 235 41122 Modena Italy Tel. +39 059 420411 Fax +39 059 253973 www.microdetectors.com info@microdetectors.com	LS2 SERIES SAFETY LIGHT CURTAIN TYPE 2	LANGUAGE
		Installation and Operation Manual	ENGLISH

7.0 TECHNICAL SPECIFICATIONS.





LS2 SERIES		TECHNICAL SPECIFICATIONS			
PARAMETERS		Min.	Nom.	Max.	NOTES
Power supply					
Supply voltage	V_{DC}	19.2	24	28.8	From PELV power supply according to EN 60204-1 Chap.6.4
Residual ripple	V			1.2	The limits of the supply voltage must not be exceeded
Absorbed power, Receiver	W			2	Excluding the load
Absorbed power, Emitter	W			1	
Absorbed power, Heater	W	2		10	Models H, IP69K with heater, see Chap.:10, Tab.: 4
Outputs (OSSDs)					
Output type		2 x PNP			Completely protected safety outputs.
Current	mA			400	Higher values are interpreted as overload or shorting
Voltage drop @400mA	V			1.2	Reduction in output voltage compared to the supply voltage
Equivalent resistive load	Ω	60			Lower values are interpreted as shorting
Leakage current	mA			2	Value at which the OFF state of the load must be guaranteed
Voltage OFF	V			0.5	Value at which the OFF state of the load must be guaranteed
Tolerated capacitive load	μF			0.82	Higher values can be interpreted as shorting.
Reaction times					
Time delay before availability	ms			500	After application of the power supply
DARK response time (OSSDs OFF)	ms	2.5		20	Depending on the number of optics, see tables in Chap.9
LIGHT response time (OSSDs ON)	ms		400		It guarantees this minimum duration of DARK pulse
Duration of the test pulse of OSSDs	μs			100	Should be ignored by downstream devices.
Restart control duration	s	0.1		5	Valid for input sequence L▶H▶L and indicated duration H
Test input signal duration	ms	4			Valid if it has at least the stated duration
Safety parameters					
Type		2			IEC 61496-1, 2004; IEC 61496-2, 2006
Optical beam angle	Deg.			±5°	IEC 61496-2, 2006
Incoherent light emitted	nm	950			LED, RG 0 (Exempt Group), IEC 62471: 2006-07
Internal self-test period	s	0.5			IEC 61496-1, 2004
Safety integrity level		SIL 2			IEC 61508, 1998
Safety integrity level		SILCL 2			IEC 62061, 2005
Performance level		PL d			ISO 13849-1 2006
Class		2			ISO 13849-1 2006
Reliability, MTTFd	Years	100			ISO 13849-1 2006
Resistance to faults in com. mode, CCF	Score	80			ISO 13849-1 2006, IEC 62061, 2005 (min. score: 65)
Service time, T_M	Years	20			ISO 13849-1 2006
Ambient					
Artificial light immunity		Acc. to IEC 61496-2			It respects the limits and conditions of the stated standard
Natural light immunity		Acc. to IEC 61496-2			It respects the limits and conditions of the stated standard
Models with standard protection		IP65 and IP67			Dust and water protection (immersion at 1m for 60min.)
Models with special protection		IP65, IP67, IP69K			Transparent casing withstanding high-pressure washing (100 bar)
Working temperature	°C	-10		55	Without condensation
Working temperature IP69K models	°C	-10		55	Without condensation, models without heater
Working temperature IP69K models	°C	-25		55	Models with thermostatic heating
Storage temperature	°C	-25		70	To be respected also during transportation
Humidity	%			95	Without condensation
Vibration		Acc. to IEC 61496-1			It respects the limits and conditions of the stated standard
Impact		Acc. to IEC 61496-1			It respects the limits and conditions of the stated standard
Range correction factors					
Use of diverter mirrors		0.85			For each diversion with a mirror
Environmental factors		0.50 / 0.25			For the presence of dust, vapours / mist, fumes (indicative)
Connections					
	mm²	0,34			To ensure the stated maximum length
Total length of cables for supply&output	m			100	With cables of indicated section
Intermediate cable length (extensions)	m			50	With cables of indicated section
Dimensions / Materials, IP67 models					
Housing section	mm	28 (front) x 30			Painted aluminium; colour: yellow RAL 1012
Groove for fixing	mm	2/10/7			One in the posterior side, depth / width / width of entry
Front window width	mm	18mm			Useful central width 13mm: material: PMMA IR
End closings	No.	2			Material: PP + 30%GF
Closing screws	No.	4+4			Material: Burnished FE37
Dimensions / Materials, IP69K models					
Housing	mm	Ø56			Material: PMMA
Sealing caps	N°	2			Material: POM C , silicone gaskets
Bridles and screws	N°	2			Material: stainless steel AISI 316L 1.4404
Connectors					
Models: LS2E/...., B, F		1xM12 5p male		Material: Nickel-plated brass	
Models: LS2E/...., M, S		2xM12 5p male			
Models: LS2R/....B, F		1xM12 5p male			
Models: LS2R/....		1xM12 8p male			
Models: LS2R/....M		1xM12 8p male			
Models: LS2R/....S		1xM12 5p male			
Modelli: LS2E/....K		Cable			Material: PVC, Ø 5mm, L 10m, 5 poles, 0,34mm ²
Modelli: LS2R/....K		Cable			Material: PVC, Ø 5mm, L 10m, 8 poles, 0,34mm ²
Modelli: LS2E/....H		Cable			Material: PVC, Ø 6mm, L 10m, 8 poles, 0,34mm ²
Modelli: LS2R/....H		Cable			Material: PVC, Ø 6mm, L 10m, 10 poles, 0,34mm ²

Tab.:1; Chap.:7

 Micro Detectors Italian Sensors Technology	M.D. Micro Detectors Strada S. Caterina, 235 41122 Modena Italy Tel. +39 059 420411 Fax +39 059 253973 www.microdetectors.com info@microdetectors.com	LS2 SERIES SAFETY LIGHT CURTAIN TYPE 2	LANGUAGE
		Installation and Operation Manual	







8.0 PANEL AND DIAGNOSTICS INDICATIONS

8.1 Symbols used to indicate the LED indicators modes

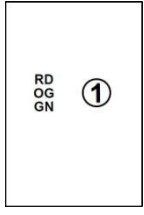





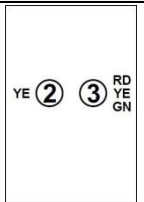

	Indication of LED lit steadily
	Indication of LED lit intermittently with periodical blinking. The number of consecutive blinks in the period indicates an error code, see Tab.: 7 and 8
	Indication of LED with continual blinking It is indicative of a specific error code, see Tab.: 7
	Indication of LED off

Tab.:1; Chap.:8











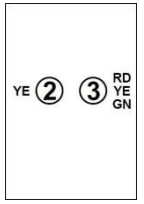

8.2 Indications of the panels

LS2 SERIES				EMITTER MODELS DISPLAY		
Display		LED_1 colour and blink		Meaning		
 RD OG GN ①	RED or ORANGE		RED at Power_ON, as initial test of LEDs for Standard and Master models ORANGE at Power_ON as initial test of LEDs for Slave models			
	GREEN		Later during Power_ON, double initial blink if the high range is chosen			
	GREEN		Standard operation			
	ORANGE		Test in progress (test contact open, the test contact must remain closed during Power-ON otherwise an error code is signalled)			
	RED		Fault condition, see the corresponding error code in Tab.:6			
	ORANGE		Fault condition, see the corresponding error code in Tab.:6			

Tab.:2; Chap.:8











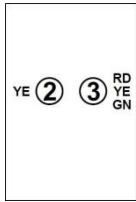



LS2 SERIES				RECEIVER MODELS DISPLAY			
Display		LED_2 colour and blink		LED_3 colour and blink		Meaning	
						For wiring of the Base Model see Tab.:2; Chap.:6	
 YE ② ③ RD YE GN	YELLOW			RED	Power_ON, as initial test of LEDs		
	OFF			RED	Broken beams, DARK and OSSDs OFF: "BREAK"		
	OFF			GREEN	Clear beams, LIGHT for slave models, (for Master see Tab.:5) Clear beams, LIGHT and OSSDs ON: "GUARD" for Base models		
	OFF			RED	Fault condition, see the corresponding error code in Tab.:7		

Tab.:3; Chap.:8

LS2 SERIES				RECEIVER MODELS DISPLAY					
Display		Colour LED_2 Blink		Colour LED_3 Blink		Meaning		Wiring See Tab.:1 Chap.:6	
 YE ② ③ RD YE GN	YELLOW			RED	Power_ON, as initial test of LEDs			1, 2, 3, 4	
	OFF			RED	Broken beams, DARK, OSSDs OFF: "BREAK"			1, 2, 3, 4	
	YELLOW			OFF	With manual Restart, with o without EDM. Clear beams, LIGHT, OSSDs OFF: "CLEAR", awaiting RESTART			3, 4	
	YELLOW			YELLOW	With automatic restart and EDM Signal level high, LIGHT, OSSDs OFF: "CLEAR", awaiting EDM closed			2	
	OFF			GREEN	Clear beams, LIGHT, OSSDs ON: "GUARD"			1, 2, 3, 4	
	OFF			RED	Fault condition, see the corresponding error code in Tab.:7			1, 2, 3, 4	





Tab.:4; Chap.:8

 M.D. Micro Detectors Strada S. Caterina, 235 41122 Modena Italy Tel. +39 059 420411 Fax +39 059 253973 www.microdetectors.com info@microdetectors.com	LS2 SERIES SAFETY LIGHT CURTAIN TYPE 2		LANGUAGE
	Installation and Operation Manual		ENGLISH





LS2 SERIES		RECEIVER MODELS DISPLAY				
		Master models: LS2R/**.***M				
Display	Colour LED_2 Blink	Colour LED_3 Blink	Meaning		Wiring See Tab.:1 Chap.:6	
 YE ② ③ RD YE GN	YELLOW			RED	Power_ON, as initial test of LEDs	1, 2, 3, 4
	OFF			RED	Broken beams of the Master section, DARK, OSSDs OFF: "BREAK"	1, 2, 3, 4
	YELLOW			RED	Broken beams of Slave sections only, DARK, OSSDs OFF: "BREAK"	1, 2, 3, 4
	YELLOW			OFF	With manual Restart, with o without EDM. Clear beams, LIGHT, OSSDs OFF: "CLEAR", awaiting RESTART	3, 4
	YELLOW			YELLOW	With automatic restart and EDM Signal level high, LIGHT, OSSDs OFF: "CLEAR", awaiting EDM closed	2
	OFF			GREEN	Clear beams, LIGHT, OSSDs ON: "GUARD"	1, 2, 3, 4
	OFF			RED	Fault condition, see the corresponding error code in Tab.:7	1, 2, 3, 4

Tab.:5; Chap.:8

8.3 Interpretation of error codes

LS2 SERIES		EMITTER MODELS ERROR CODES			
Model	LED_1 colour and blink	No. Pulses	Meaning		Indications
ALL	RED		2	Abnormal levels on pins 2 and 4	Switch off, check the wiring, restart
ALL	RED		3/4	Internal failure	Send for repairs
ALL	RED		5	Master and Slave not compatible	Switch off, check the compatibility of the connected models, replace, restart
MASTER SLAVES	ORANGE		2	Unstable communication	Switch off, check the wiring, restart
SLAVES	ORANGE		∞	Master and Slave lose communication	Switch off, check the wiring, restart
NOTE:	In all these cases, if the failure persists, send to M. D. Micro Detectors for repair				

Tab.:6; Chap.:9

LS2 SERIES		RECEIVER MODELS ERROR CODES			
Model	LED_3 colour and blink	No. Pulses	Meaning		Indications
ALL	RED		2	Wrong configuration.	Switch off, check the wiring, restart
ALL	RED		4	Optical interference detected	See note
MASTER STANDARD BASE	RED		5	Failure on the OSSD outputs	Switch off, check the wiring, compatibility of the loads, restart
ALL	RED		6/7	Internal failure.	Send for repairs
MASTER SLAVES	RED		8	Incorrect connections between Master and Slave	Switch off, check the wiring, restart
NOTE:	<p>In case of optical interference, identify the interfering source and proceed as follows:</p> <ul style="list-style-type: none"> • Reduce the range of the interfering Emitter. • Modify the alignment and/or position of the interfering elements so as to reduce the signal, without impairing the normal operation of the pairs. • Shield the interfering Emitter from the view of the Receiver (given the small beam angles a small sheet of opaque material should suffice placed behind the Emitter paired with the interfered Receiver). • Swap over the positions of the Emitter/Receiver of one of the pairs. <p>In case of failure, if the malfunction persists, send to M. D. Micro Detectors for repair.</p>				

Tab.:7; Chap.:8

 Micro Detectors Italian Sensors Technology	M.D. Micro Detectors Strada S. Caterina, 235 41122 Modena Italy Tel. +39 059 420411 Fax +39 059 253973 www.microdetectors.com info@microdetectors.com	LS2 SERIES SAFETY LIGHT CURTAIN TYPE 2	LANGUAGE
		Installation and Operation Manual	ENGLISH

9.0 LISTS OF AVAILABLE MODELS AND MAIN CHARACTERISTICS

LS2 SERIES SAFETY LIGHT CURTAIN FOR HAND PROTECTION WITH RESOLUTION 30mm													
PAIRED MODELS	LS2	ER	/	30	-	015	to	180	B	M	S	F	
FUNCTIONS: optical heights from 150mm to 1800mm; standard, Base, Master, Intermediate Slave, Final Slave; automatic restart; manual restart and EDM can be selected with wiring; standard range.													
MODELS	BEAMS	RESOLUTION	OPTICAL HEIGHT	HOUSING HEIGHT	RANGE	RESPONSE TIME	PFH _d	DC _{avg}	MTTF _d	CCF	Connectors		NOTES
											Em.	Rec.	
	No.	mm	mm	mm	m	ms	F/h	%	years	Score	No., Ø, Poles		
LS2ER/30-015B	8	30	160	213	0 to 4/0 to 12	4.5	2,04E-08	91.3	100	80	1x M12-5	1x M12-5	Only automatic restart without EDM
LS2ER/30-015				213		4.5					1x M12-5	1x M12-8	Standard model, all functions
-				-		-					-	-	Master not available
LS2ER/30-015F				213		+1.76					1x M12-5	1x M12-5	Final Slave
-				-		-					-	-	Intermediate Slave not available
LS2ER/30-030B	16	30	310	363	0 to 4/0 to 12	6	2,65E-08	91.1	100	80	1x M12-5	1x M12-5	Only automatic restart without EDM
LS2ER/30-030				363		6					1x M12-5	1x M12-8	Standard model, all functions
LS2ER/30-030M				386.5		6					2x M12-5	1x M12-5 1x M12-8	Master model, all functions
LS2ER/30-030F				363		+3.53					1x M12-5	1x M12-5	Final Slave
LS2ER/30-030S				386.5		+3.96					2x M12-5	2x M12-5	Intermediate Slave
LS2ER/30-045B	23	30	460	513	0 to 4/0 to 12	8	3,29E-08	90.9	100	80	1x M12-5	1x M12-5	Only automatic restart without EDM
LS2ER/30-045				513		8					1x M12-5	1x M12-8	Standard model, all functions
LS2ER/30-045M				536.5		8					2x M12-5	1x M12-5 1x M12-8	Master model, all functions
LS2ER/30-045F				513		+5.07					1x M12-5	1x M12-5	Final Slave
LS2ER/30-045S				536.5		+5.51					2x M12-5	2x M12-5	Intermediate Slave
LS2ER/30-060B	31	30	610	663	0 to 4/0 to 12	10	3,90E-08	90.7	100	80	1x M12-5	1x M12-5	Only automatic restart without EDM
LS2ER/30-060				663		10					1x M12-5	1x M12-8	Standard model, all functions
LS2ER/30-060M				686.5		10					2x M12-5	1x M12-5 1x M12-8	Master model, all functions
LS2ER/30-060F				663		+6.84					1x M12-5	1x M12-5	Final Slave
LS2ER/30-060S				686.5		+7.284					2x M12-5	2x M12-5	Intermediate Slave
LS2ER/30-075B	38	30	760	813	0 to 4/0 to 12	11	4,54E-08	90.6	100	80	1x M12-5	1x M12-5	Only automatic restart without EDM
LS2ER/30-075				813		11					1x M12-5	1x M12-8	Standard model, all functions
LS2ER/30-075M				836.5		11					2x M12-5	1x M12-5 1x M12-8	Master model, all functions
LS2ER/30-075F				813		+8.39					1x M12-5	1x M12-5	Final Slave
LS2ER/30-075S				836.5		+8.82					2x M12-5	2x M12-5	Intermediate Slave
LS2ER/30-090B	46	30	910	963	0 to 4/0 to 12	13	5,15E-08	90.6	100	80	1x M12-5	1x M12-5	Only automatic restart without EDM
LS2ER/30-090				963		13					1x M12-5	1x M12-8	Standard model, all functions
LS2ER/30-090M				986.5		13					2x M12-5	1x M12-5 1x M12-8	Master model, all functions
LS2ER/30-090F				963		+10.15					1x M12-5	1x M12-5	Final Slave
LS2ER/30-090S				986.5		+10.59					2x M12-5	2x M12-5	Intermediate Slave
LS2ER/30-105B	53	30	1060	1113	0 to 4/0 to 12	14.5	5,78E-08	90.5	100	80	1x M12-5	1x M12-5	Only automatic restart without EDM
LS2ER/30-105				1113		14.5					1x M12-5	1x M12-8	Standard model, all functions
LS2ER/30-105M				1136.5		14.5					2x M12-5	1x M12-5 1x M12-8	Master model, all functions
LS2ER/30-105F				1113		+11.70					1x M12-5	1x M12-5	Final Slave
LS2ER/30-105S				1136.5		+12.13					2x M12-5	2x M12-5	Intermediate Slave
LS2ER/30-120B	61	30	1210	1263	0 to 4/0 to 12	16	6,39E-08	90.5	100	80	1x M12-5	1x M12-5	Only automatic restart without EDM
LS2ER/30-120				1263		16					1x M12-5	1x M12-8	Standard model, all functions
LS2ER/30-120M				1286.5		16					2x M12-5	1x M12-5 1x M12-8	Master model, all functions
LS2ER/30-120F				1263		+13.46					1x M12-5	1x M12-5	Final Slave
LS2ER/30-120S				1286.5		+13.90					2x M12-5	2x M12-5	Intermediate Slave
LS2ER/30-135B	68	30	1360	1413	0 to 4/0 to 12	17.5	7,03E-08	90.4	100	80	1x M12-5	1x M12-5	Only automatic restart without EDM
LS2ER/30-135				1413		17.5					1x M12-5	1x M12-8	Standard model, all functions
LS2ER/30-135M				1436.5		17.5					2x M12-5	1x M12-5 1x M12-8	Master model, all functions
LS2ER/30-135F				1413		+15.01					1x M12-5	1x M12-5	Final Slave
LS2ER/30-135S				1436.5		+15.45					2x M12-5	2x M12-5	Intermediate Slave
LS2ER/30-150B	76	30	1510	1563	0 to 4/0 to 12	19.5	7,64E-08	90.4	100	80	1x M12-5	1x M12-5	Only automatic restart without EDM
LS2ER/30-150				1563		19.5					1x M12-5	1x M12-8	Standard model, all functions
LS2ER/30-150M				1586.5		19.5					2x M12-5	1x M12-5 1x M12-8	Master model, all functions
LS2ER/30-150F				1563		+16.78					1x M12-5	1x M12-5	Final Slave
LS2ER/30-150S				1586.5		+17.21					2x M12-5	2x M12-5	Intermediate Slave

 Micro Detectors Italian Sensors Technology	M.D. Micro Detectors Strada S. Caterina, 235 41122 Modena Italy Tel. +39 059 420411 Fax +39 059 253973 www.microdetectors.com info@microdetectors.com	LS2 SERIES SAFETY LIGHT CURTAIN TYPE 2	LANGUAGE
		Installation and Operation Manual	ENGLISH

LS2ER/30-165	83	30	1660	1713	0÷4 / 0÷12	21	8,35E-08	90,4	100	80	1x M12-5	1x M12-8	Standard model, all functions
LS2ER/30-180	91	30	1810	1863	0÷4 / 0÷12	22,5	8,98E-08	90,3	100	80	1x M12-5	1x M12-8	Standard model, all functions

Tab.:1; Chap.:9

LS2 SERIES SAFETY LIGHT CURTAIN FOR HAND PROTECTION WITH RESOLUTION 40mm															
PAIRED MODELS	LS2	ER	/	40	-	015	to	150	B	M	S	F			
FUNCTIONS: optical heights from 150mm to 1500mm; standard, Base, Master, Intermediate Slave, Final Slave; automatic restart; manual restart and EDM can be selected with wiring; standard range.															
MODELS	BEAMS	RESOLUTION	OPTICAL HEIGHT	HOUSING HEIGHT	RANGE	RESPONSE TIME	PFH _d	DC _{avg}	MTTF _d	CCF	Connectors		NOTES		
											Em.	Rec.			
	No.	mm	mm	mm	m	ms	F/h	%	years	Score	No., Ø,	Poles			
LS2ER/40-015B	6	40	160	213	0 to 4 / 0 to 12	4	1.83E-08	94.6	100	80	1x M12-5	1x M12-5	Only automatic restart without EDM		
LS2ER/40-015				213		4					1x M12-5	1x M12-8	Standard model, all functions		
-				-		-					-	-	-	-	Master not available
LS2ER/40-015F				213		+1.32					1x M12-5	1x M12-5	Final Slave		
-				-		-					-	-	Intermediate Slave not available		
LS2ER/40-030B	11	40	310	363	0 to 4 / 0 to 12	5	2.29E-08	93.8	100	80	1x M12-5	1x M12-5	Only automatic restart without EDM		
LS2ER/40-030				363		5					1x M12-5	1x M12-8	Standard model, all functions		
LS2ER/40-030M				386.5		5					2x M12-5	1x M12-5 1x M12-8	Master model, all functions		
LS2ER/40-030F				363		+2.42					1x M12-5	1x M12-5	Final Slave		
LS2ER/40-030S				386.5		+2.86					2x M12-5	2x M12-5	Intermediate Slave		
LS2ER/40-045B	16	40	460	513	0 to 4 / 0 to 12	6	2.73E-08	93.2	100	80	1x M12-5	1x M12-5	Only automatic restart without EDM		
LS2ER/40-045				513		6					1x M12-5	1x M12-8	Standard model, all functions		
LS2ER/40-045M				536.5		6					2x M12-5	1x M12-5 1x M12-8	Master model, all functions		
LS2ER/40-045F				513		+3.53					1x M12-5	1x M12-5	Final Slave		
LS2ER/40-045S				536.5		+3.96					2x M12-5	2x M12-5	Intermediate Slave		
-												-		-	
LS2ER/40-060B	21	40	610	663	0 to 4 / 0 to 12	7.5	3.18E-08	92.8	100	80	1x M12-5	1x M12-5	Only automatic restart without EDM		
LS2ER/40-060				663		7.5					1x M12-5	1x M12-8	Standard model, all functions		
LS2ER/40-060M				686.5		7.5					2x M12-5	1x M12-5 1x M12-8	Master model, all functions		
LS2ER/40-060F				663		+4.63					1x M12-5	1x M12-5	Final Slave		
LS2ER/40-060				686.5		+5.074					2x M12-5	2x M12-5	Intermediate Slave		
LS2ER/40-075B	26	40	760	813	0 to 4 / 0 to 12	8.5	3.63E-08	92.4	100	80	1x M12-5	1x M12-5	Only automatic restart without EDM		
LS2ER/40-075				813		8.5					1x M12-5	1x M12-8	Standard model, all functions		
LS2ER/40-075M				836.5		8.5					2x M12-5	1x M12-5 1x M12-8	Master model, all functions		
LS2ER/40-075F				813		+5.74					1x M12-5	1x M12-5	Final Slave		
LS2ER/40-075S				836.5		+6.17					2x M12-5	2x M12-5	Intermediate Slave		
-												-		-	
LS2ER/40-090B	31	40	910	963	0 to 4 / 0 to 12	9.5	4.08E-08	92.2	100	80	1x M12-5	1x M12-5	Only automatic restart without EDM		
LS2ER/40-090				963		9.5					1x M12-5	1x M12-8	Standard model, all functions		
LS2ER/40-090M				986.5		9.5					2x M12-5	1x M12-5 1x M12-8	Master model, all functions		
LS2ER/40-090F				963		+6.84					1x M12-5	1x M12-5	Final Slave		
LS2ER/40-090S				986.5		+7.28					2x M12-5	2x M12-5	Intermediate Slave		
LS2ER/40-105B	36	40	1060	1113	0 to 4 / 0 to 12	10.5	4.53E-08	92.0	100	80	1x M12-5	1x M12-5	Only automatic restart without EDM		
LS2ER/40-105				1113		10.5					1x M12-5	1x M12-8	Standard model, all functions		
LS2ER/40-105M				1136.5		10.5					2x M12-5	1x M12-5 1x M12-8	Master model, all functions		
LS2ER/40-105F				1113		+7.94					1x M12-5	1x M12-5	Final Slave		
LS2ER/40-105S				1136.5		+8.38					2x M12-5	2x M12-5	Intermediate Slave		
LS2ER/40-120B	41	40	1210	1263	0 to 4 / 0 to 12	11.5	4.98E-08	91.8	100	80	1x M12-5	1x M12-5	Only automatic restart without EDM		
LS2ER/40-120				1263		11.5					1x M12-5	1x M12-8	Standard model, all functions		
LS2ER/40-120M				1286.5		11.5					2x M12-5	1x M12-5 1x M12-8	Master model, all functions		
LS2ER/40-120F				1263		+9.05					1x M12-5	1x M12-5	Final Slave		
LS2ER/40-120S				1286.5		+9.48					2x M12-5	2x M12-5	Intermediate Slave		

 Micro Detectors Italian Sensors Technology	M.D. Micro Detectors Strada S. Caterina, 235 41122 Modena Italy Tel. +39 059 420411 Fax +39 059 253973 www.microdetectors.com info@microdetectors.com	LS2 SERIES SAFETY LIGHT CURTAIN TYPE 2	LANGUAGE
		Installation and Operation Manual	ENGLISH

LS2ER/40-135B	46	40	1360	1413	0 to 4 / 0 to 12	13	5.43E-08	91.7	100	80	1x M12-5	1x M12-5	Only automatic restart without EDM
LS2ER/40-135				1413		13					1x M12-5	1x M12-8	Standard model, all functions
LS2ER/40-135M				1436.5		13					2x M12-5	1x M12-5 1x M12-8	Master model, all functions
LS2ER/40-135F				1413		+10.15					1x M12-5	1x M12-5	Final Slave
LS2ER/40-135S				1436.5		+10.59					2x M12-5	2x M12-5	Intermediate Slave
LS2ER/40-150B	51	40	1510	1563	0 to 4 / 0 to 12	14	5.88E-08	91.5	100	80	1x M12-5	1x M12-5	Only automatic restart without EDM
LS2ER/40-150				1563		14					1x M12-5	1x M12-8	Standard model, all functions
LS2ER/40-150M				1586.5		14					2x M12-5	1x M12-5 1x M12-8	Master model, all functions
LS2ER/40-150F				1563		+11.26					1x M12-5	1x M12-5	Final Slave
LS2ER/40-150S				1586.5		+11.69					2x M12-5	2x M12-5	Intermediate Slave

Tab.:2; Chap.:9

LS2 SERIES SAFETY LIGHT CURTAIN FOR LIMB PROTECTION WITH RESOLUTION 50mm													
PAIRED MODELS	LS2	ER	/	50	-	015	to	150	B	M	S	F	
FUNCTIONS: optical heights from 150mm to 1500mm; standard, Base, Master, Intermediate Slave, Final Slave; automatic restart; manual restart and EDM can be selected with wiring; standard range.													
MODELS	BEAMS	RESOLUTION	OPTICAL HEIGHT	HOUSING HEIGHT	RANGE	RESPONSE TIME	PFH _d	DC _{avg}	MTTF _d	CCF	Connectors		NOTES
											Em.	Rec.	
											No., mm	No., Ø, Poles	
LS2ER/50-015B	4	50	160	213	0 to 4 / 0 to 12	3.5	1.75E-08	94.8	100	80	1x M12-5	1x M12-5	Only automatic restart without EDM
LS2ER/50-015				213		3.5					1x M12-5	1x M12-8	Standard model, all functions
-				-		-					-	-	Master not available
LS2ER/50-015F				213		+0.88					1x M12-5	1x M12-5	Final Slave
-				-		-					-	-	Intermediate Slave not available
LS2ER/50-030B	8	50	310	363	0 to 4 / 0 to 12	4.5	2.13E-08	94.0	100	80	1x M12-5	1x M12-5	Only automatic restart without EDM
LS2ER/50-030				363		4.5					1x M12-5	1x M12-8	Standard model, all functions
LS2ER/50-030M				386.5		4.5					2x M12-5	1x M12-5 1x M12-8	Master model, all functions
LS2ER/50-030F				363		+1.76					1x M12-5	1x M12-5	Final Slave
LS2ER/50-030S				386.5		+2.20					2x M12-5	2x M12-5	Intermediate Slave
LS2ER/50-045B	12	50	460	513	0 to 4 / 0 to 12	5.5	2.47E-08	93.5	100	80	1x M12-5	1x M12-5	Only automatic restart without EDM
LS2ER/50-045				513		5.5					1x M12-5	1x M12-8	Standard model, all functions
LS2ER/50-045M				536.5		5.5					2x M12-5	1x M12-5 1x M12-8	Master model, all functions
LS2ER/50-045F				513		+2.64					1x M12-5	1x M12-5	Final Slave
LS2ER/50-045S				536.5		+3.08					2x M12-5	2x M12-5	Intermediate Slave
LS2ER/50-060B	16	50	610	663	0 to 4 / 0 to 12	6	2.85E-08	93.1	100	80	1x M12-5	1x M12-5	Only automatic restart without EDM
LS2ER/50-060				663		6					1x M12-5	1x M12-8	Standard model, all functions
LS2ER/50-060M				686.5		6					2x M12-5	1x M12-5 1x M12-8	Master model, all functions
LS2ER/50-060F				663		+3.53					1x M12-5	1x M12-5	Final Slave
LS2ER/50-060S				686.5		+3.96					2x M12-5	2x M12-5	Intermediate Slave
LS2ER/50-075B	20	50	760	813	0 to 4 / 0 to 12	7	3.19E-08	92.8	100	80	1x M12-5	1x M12-5	Only automatic restart without EDM
LS2ER/50-075				813		7					1x M12-5	1x M12-8	Standard model, all functions
LS2ER/50-075M				836.5		7					2x M12-5	1x M12-5 1x M12-8	Master model, all functions
LS2ER/50-075F				813		+4.41					1x M12-5	1x M12-5	Final Slave
LS2ER/50-075S				836.5		+4.85					2x M12-5	2x M12-5	Intermediate Slave
LS2ER/50-090B	24	50	910	963	0 to 4 / 0 to 12	8	3.57E-08	92.5	100	80	1x M12-5	1x M12-5	Only automatic restart without EDM
LS2ER/50-090				963		8					1x M12-5	1x M12-8	Standard model, all functions
LS2ER/50-090M				986.5		8					2x M12-5	1x M12-5 1x M12-8	Master model, all functions
LS2ER/50-090F				963		+5.29					1x M12-5	1x M12-5	Final Slave
LS2ER/50-090S				986.5		+5.73					2x M12-5	2x M12-5	Intermediate Slave
LS2ER/50-105B	28	50	1060	1113	0 to 4 / 0 to 12	9	3.91E-08	92.3	100	80	1x M12-5	1x M12-5	Only automatic restart without EDM
LS2ER/50-105				1113		9					1x M12-5	1x M12-8	Standard model, all functions
LS2ER/50-105M				1136.5		9					2x M12-5	1x M12-5 1x M12-8	Master model, all functions
LS2ER/50-105F				1113		+6.18					1x M12-5	1x M12-5	Final Slave
LS2ER/50-105S				1136.5		+6.61					2x M12-5	2x M12-5	Intermediate Slave
LS2ER/50-120B	32	50	1210	1263	0 to 4 / 0 to 12	10	4.29E-08	92.1	100	80	1x M12-5	1x M12-5	Only automatic restart without EDM
LS2ER/50-120				1263		10					1x M12-5	1x M12-8	Standard model, all functions
LS2ER/50-120M				1286.5		10					2x M12-5	1x M12-5 1x M12-8	Master model, all functions
LS2ER/50-120F				1263		+7.06					1x M12-5	1x M12-5	Final Slave
LS2ER/50-120S				1286.5		+7.50					2x M12-5	2x M12-5	Intermediate Slave

 Micro Detectors Italian Sensors Technology	M.D. Micro Detectors Strada S. Caterina, 235 41122 Modena Italy Tel. +39 059 420411 Fax +39 059 253973 www.microdetectors.com info@microdetectors.com	LS2 SERIES SAFETY LIGHT CURTAIN TYPE 2				LANGUAGE
		Installation and Operation Manual				ENGLISH

LS2ER/50-135B	36	50	1360	1413	0 to 4 / 0 to 12	10.5	4.63E-08	91.9	100	80	1x M12-5	1x M12-5	Only automatic restart without EDM
LS2ER/50-135				1413		10.5					1x M12-5	1x M12-8	Standard model, all functions
LS2ER/50-135M				1436,5		10.5					2x M12-5	1x M12-5 1x M12-8	Master model, all functions
LS2ER/50-135F				1413		+7.94					1x M12-5	1x M12-5	Final Slave
LS2ER/50-135S				1436,5		+8.38					2x M12-5	2x M12-5	Intermediate Slave
LS2ER/50-150B	40	50	1510	1563	0 to 4 / 0 to 12	11.5	5.01E-08	91.8	100	80	1x M12-5	1x M12-5	Only automatic restart without EDM
LS2ER/50-150				1563		11.5					1x M12-5	1x M12-8	Standard model, all functions
LS2ER/50-150M				1586,5		11.5					2x M12-5	1x M12-5 1x M12-8	Master model, all functions
LS2ER/50-150F				1563		+8.83					1x M12-5	1x M12-5	Final Slave
LS2ER/50-150S				1586,5		+9.26					2x M12-5	2x M12-5	Intermediate Slave

Tab.:3; Chap.:9

LS2 SERIES SAFETY LIGHT CURTAIN FOR LIMB PROTECTION WITH RESOLUTION 90mm													
PAIRED MODELS	LS2	ER	/	90	-	015	to	150	B	M	S	F	
FUNCTIONS: optical heights from 150mm to 1500mm; standard, Base, Master, Intermediate Slave, Final Slave; automatic restart; manual restart and EDM can be selected with wiring; standard range.													
MODELS	BEAMS	RESOLUTION	OPTICAL HEIGHT	HOUSING HEIGHT	RANGE	RESPONSE TIME	PFH _d	DC _{avg}	MTTF _d	CCF	Connectors		NOTES
											Em.	Rec.	
No.	mm	mm	mm	m	ms	F/h	%	Years	Score	No., Ø, Poles			
LS2ER/90-030B	4	90	310	363	0 to 4 / 0 to 12	3,5	1.82E-08	94,7	100	80	1x M12-5	1x M12-5	Only automatic restart without EDM
LS2ER/90-030				363		3,5					1x M12-5	1x M12-8	Standard model, all functions
LS2ER/90-030M				386,5		3,5					2x M12-5	1x M12-5 1x M12-8	Master model, all functions
LS2ER/90-030F				363		+0,88					1x M12-5	1x M12-5	Final Slave
LS2ER/90-030S				386,5		+1,32					2x M12-5	2x M12-5	Intermediate Slave
LS2ER/90-045B	6	90	460	513	0 to 4 / 0 to 12	4	2.05E-08	94,2	100	80	1x M12-5	1x M12-5	Only automatic restart without EDM
LS2ER/90-045				513		4					1x M12-5	1x M12-8	Standard model, all functions
LS2ER/90-045M				536,5		4					2x M12-5	1x M12-5 1x M12-8	Master model, all functions
LS2ER/90-045F				513		+1,32					1x M12-5	1x M12-5	Final Slave
LS2ER/90-045S				536,5		+1,76					2x M12-5	2x M12-5	Intermediate Slave
LS2ER/90-060B	8	90	610	663	0 to 4 / 0 to 12	4,5	2.27E-08	93,8	100	80	1x M12-5	1x M12-5	Only automatic restart without EDM
LS2ER/90-060				663		4,5					1x M12-5	1x M12-8	Standard model, all functions
LS2ER/90-060M				686,5		4,5					2x M12-5	1x M12-5 1x M12-8	Master model, all functions
LS2ER/90-060F				663		+1,76					1x M12-5	1x M12-5	Final Slave
LS2ER/90-060S				686,5		+2,2					2x M12-5	2x M12-5	Intermediate Slave
LS2ER/90-075B	10	90	760	813	0 to 4 / 0 to 12	5	2.50E-08	93,5	100	80	1x M12-5	1x M12-5	Only automatic restart without EDM
LS2ER/90-075				813		5					1x M12-5	1x M12-8	Standard model, all functions
LS2ER/90-075M				836,5		5					2x M12-5	1x M12-5 1x M12-8	Master model, all functions
LS2ER/90-075F				813		+2,20					1x M12-5	1x M12-5	Final Slave
LS2ER/90-075S				836,5		+2,64					2x M12-5	2x M12-5	Intermediate Slave
LS2ER/90-090B	12	90	910	963	0 to 4 / 0 to 12	5,5	2.72E-08	93,2	100	80	1x M12-5	1x M12-5	Only automatic restart without EDM
LS2ER/90-090				963		5,5					1x M12-5	1x M12-8	Standard model, all functions
LS2ER/90-090M				986,5		5,5					2x M12-5	1x M12-5 1x M12-8	Master model, all functions
LS2ER/90-090F				963		+2,64					1x M12-5	1x M12-5	Final Slave
LS2ER/90-090S				986,5		+3,08					2x M12-5	2x M12-5	Intermediate Slave
LS2ER/90-105B	14	90	1060	1113	0 to 4 / 0 to 12	6	2.95E-08	93,0	100	80	1x M12-5	1x M12-5	Only automatic restart without EDM
LS2ER/90-105				1113		6					1x M12-5	1x M12-8	Standard model, all functions
LS2ER/90-105M				1136,5		6					2x M12-5	1x M12-5 1x M12-8	Master model, all functions
LS2ER/90-105F				1113		+3,09					1x M12-5	1x M12-5	Final Slave
LS2ER/90-105S				1136,5		+3,52					2x M12-5	2x M12-5	Intermediate Slave
LS2ER/90-120B	16	90	1210	1263	0 to 4 / 0 to 12	6	3.18E-08	92,8	100	80	1x M12-5	1x M12-5	Only automatic restart without EDM
LS2ER/90-120				1263		6					1x M12-5	1x M12-8	Standard model, all functions
LS2ER/90-120M				1286,5		6					2x M12-5	1x M12-5 1x M12-8	Master model, all functions
LS2ER/90-120F				1263		+3,53					1x M12-5	1x M12-5	Final Slave
LS2ER/90-120S				1286,5		+3,96					2x M12-5	2x M12-5	Intermediate Slave
LS2ER/90-135B	18	90	1360	1413	0 to 4 / 0 to 12	6,5	3.41E-08	92,6	100	80	1x M12-5	1x M12-5	Only automatic restart without EDM
LS2ER/90-135				1413		6,5					1x M12-5	1x M12-8	Standard model, all functions
LS2ER/90-135M				1436,5		6,5					2x M12-5	1x M12-5 1x M12-8	Master model, all functions
LS2ER/90-135F				1413		+3,97					1x M12-5	1x M12-5	Final Slave

 Micro Detectors Italian Sensors Technology	M.D. Micro Detectors Strada S. Caterina, 235 41122 Modena Italy Tel. +39 059 420411 Fax +39 059 253973 www.microdetectors.com info@microdetectors.com	LS2 SERIES SAFETY LIGHT CURTAIN TYPE 2						LANGUAGE
		Installation and Operation Manual						ENGLISH

LS2ER/90-135S				1436,5		+4,41							2x M12-5	2x M12-5	Intermediate Slave
LS2ER/90-150B				1563		7							1x M12-5	1x M12-5	Only automatic restart without EDM
LS2ER/90-150				1563		7							1x M12-5	1x M12-8	Standard model, all functions
-	20	90	1510	-	0 to 4 / 0 to 12	-									Master not available
-				-		-									Intermediate Slave not available
-				-		-									Intermediate Slave not available

Tab.:4; Chap.:9

LS2 SERIES ACCESS PROTECTION MULTI-BEAM LIGHT GRID WITH 2, 3, 4 BEAMS															
PAIRED MODELS		LS2	ER	/	0A	0B	0C	050	080	090	B	M	S	F	
FUNCTIONS: 2, 3, 4 beams; standard, Base, Master, Intermediate Slave, Final Slave; automatic restart; manual restart and EDM can be selected with wiring; standard range.															
MODELS	BEAMS	PITCH	OPTICAL HEIGHT	HOUSING HEIGHT	RANGE	RESPONSE TIME	PFH _d	DC _{avg}	MTTF _d	CCF	Connectors		NOTES		
	No.	mm	mm	mm	m	ms	F/h	%	Years	Score	Em.	Rec.			
LS2ER/0A-050B				653		3						1x M12-5	1x M12-5	Only automatic restart without EDM	
LS2ER/0A-050				653		3						1x M12-5	1x M12-8	Standard model, all functions	
LS2ER/0A-050M	2	500	510	677	0 to 4 / 0 to 12	3	1.71E-08	94,9	100	80		2x M12-5	1x M12-5 1x M12-8	Master model, all functions	
LS2ER/0A-050F				653		+0,44						1x M12-5	1x M12-5	Final Slave	
LS2ER/0A-050S				677		+0,87						2x M12-5	2x M12-5	Intermediate Slave	
LS2ER/0B-080B				953		3,5						1x M12-5	1x M12-5	Only automatic restart without EDM	
LS2ER/0B-080				953		3,5						1x M12-5	1x M12-8	Standard model, all functions	
LS2ER/0B-080M	3	400	810	977	0 to 4 / 0 to 12	3,5	1.87E-08	94,6	100	80		2x M12-5	1x M12-5 1x M12-8	Master model, all functions	
LS2ER/0B-080F				953		+0,66						1x M12-5	1x M12-5	Final Slave	
LS2ER/0B-080S				977		+1,09						2x M12-5	2x M12-5	Intermediate Slave	
LS2ER/0C-090B				1053		3,5						1x M12-5	1x M12-5	Only automatic restart without EDM	
LS2ER/0C-090				1053		3,5						1x M12-5	1x M12-8	Standard model, all functions	
LS2ER/0C-090M	4	300	910	1077	0 to 4 / 0 to 12	3,5	2.02E-08	94,2	100	80		2x M12-5	1x M12-5 1x M12-8	Master model, all functions	
LS2ER/0C-090F				1053		+0,88						1x M12-5	1x M12-5	Final Slave	
LS2ER/0C-090S				1077		+1,32						2x M12-5	2x M12-5	Intermediate Slave	

Tab.:5; Chap.:9

 Micro Detectors Italian Sensors Technology	M.D. Micro Detectors Strada S. Caterina, 235 41122 Modena Italy Tel. +39 059 420411 Fax +39 059 253973 www.microdetectors.com info@microdetectors.com	LS2 SERIES SAFETY LIGHT CURTAIN TYPE 2	LANGUAGE
		Installation and Operation Manual	

LS2 SERIES SAFETY LIGHT CURTAINS IN IP69K TRANSPARENT HOUSING WITH BEAMS IN A ROW FOR HAND PROTECTION WITH RESOLUTION 30mm													
PAIRED MODELS	LS2	ER	/	30	-	015	to	150	K				
FUNCTIONS: optical heights from 150mm to 1500mm; standard functions, automatic restart, manual restart and EDM can be selected with wiring; extended range; IP69K protection.													
MODELS	BEAMS	RESOLUTION	OPTICAL HEIGHT	HOUSING HEIGHT	RANGE	RESPONSE TIME	PFH _d	DC _{avg}	MTTF _d	CCF	Cable		NOTES
											Em.	Rec.	
											Ø, Poles		
	No.	mm	mm	mm	m	ms	F/h	%	Years	Points			
LS2ER/30-015K	8	30	160	330	0 to 3 / 0 to 10	4,5	2.04 E-08	91,3	100	80	PVC cable, length 10m, Ø5,5mm, 5-pin, 0.34 mm ² For connections see Chap.: 6, Tab.: 4 Special cable lengths 15 and 50m	PVC cable, length 10m, Ø5,5mm, 8-pin, 0.34 mm ² For connections see Chap.: 6, Tab.: 1 Special cable lengths 15 and 30m	Version IP65 + IP67, in IP69K housing. Only the standard models, all functions. Temperature -10 ... 55 ° C. For dimensions, see: Chap: 10, Fig: 6 and Table: 4
LS2ER/30-030K	16	30	310	480		6	2.65 E-08	91,1	100	80			
LS2ER/30-045K	23	30	460	630		8	3.29 E-08	90,9	100	80			
LS2ER/30-060K	31	30	610	780		10	3.90 E-08	90,7	100	80			
LS2ER/30-075K	38	30	760	930		11	4.54 E-08	90,6	100	80			
LS2ER/30-090K	46	30	910	1080		13	5.15 E-08	90,6	100	80			
LS2ER/30-105K	53	30	1060	1230		14,5	5.78 E-08	90,5	100	80			
LS2ER/30-120K	61	30	1210	1380		16	6.39 E-08	90,5	100	80			
LS2ER/30-135K	68	30	1360	1530		17,5	7.03 E-08	90,4	100	80			
LS2ER/30-150K	76	30	1510	1680		19,5	7.64 E-08	90,4	100	80			

Tab.:6; Chap.:9

LS2 SERIES SAFETY LIGHT CURTAINS IN IP69K TRANSPARENT HOUSING WITH BEAMS IN A ROW FOR HAND PROTECTION WITH RESOLUTION 30mm													
PAIRED MODELS	LS2	ER	/	30	-	015	to	150	H				
FUNCTIONS: optical heights from 150mm to 1500mm; standard functions, automatic restart, manual restart and EDM can be selected with wiring; extended range; IP69K protection and thermostat.													
MODELS	BEAMS	RESOLUTION	OPTICAL HEIGHT	HOUSING HEIGHT	RANGE	RESPONSE TIME	PFH _d	DC _{avg}	MTTF _d	CCF	Cable		NOTES
											Em.	Rec.	
											Ø, Poles		
	No.	mm	mm	mm	m	ms	F/h	%	Years	Points			
LS2ER/30-015H	8	30	160	330	0 to 3 / 0 to 10	4,5	2.04 E-08	91,3	100	80	PVC cable, length 10m, Ø6mm, 8-pin, 0.34 mm ² For connections see Chap.: 6, Tab.: 5 Special cable lengths 15 and 50m	PVC cable, length 10m, Ø6mm, 10-pin, 0.34 mm ² For connections see Chap.: 6, Tab.: 3 Special cable lengths 15 and 30m	Version IP65 + IP67, in IP69K thermostated housing Only the standard models, all functions. Temperature -25 ... 55 ° C. For dimensions, see: Chap: 10, Fig: 6 and Table: 4
LS2ER/30-030H	16	30	310	480		6	2.65 E-08	91,1	100	80			
LS2ER/30-045H	23	30	460	630		8	3.29 E-08	90,9	100	80			
LS2ER/30-060H	31	30	610	780		10	3.90 E-08	90,7	100	80			
LS2ER/30-075H	38	30	760	930		11	4.54 E-08	90,6	100	80			
LS2ER/30-090H	46	30	910	1080		13	5.15 E-08	90,6	100	80			
LS2ER/30-105H	53	30	1060	1230		14,5	5.78 E-08	90,5	100	80			
LS2ER/30-120H	61	30	1210	1380		16	6.39 E-08	90,5	100	80			
LS2ER/30-135H	68	30	1360	1530		17,5	7.03 E-08	90,4	100	80			
LS2ER/30-150H	76	30	1510	1680		19,5	7.64 E-08	90,4	100	80			

Tab.:7; Chap.:9

 Micro Detectors Italian Sensors Technology	M.D. Micro Detectors Strada S. Caterina, 235 41122 Modena Italy Tel. +39 059 420411 Fax +39 059 253973 www.microdetectors.com info@microdetectors.com	LS2 SERIES SAFETY LIGHT CURTAIN TYPE 2	LANGUAGE
		Installation and Operation Manual	

LS2 SERIES SAFETY BARRIER IN IP69K TRANSPARENT HOUSING ACCESS PROTECTION MULTI-BEAM SAFETY LIGHT GRID WITH 2, 3, 4 BEAMS													
PAIRED MODELS		LS2	ER	/	0A	0B	0C	050	080	090	K		
FUNCTIONS: optical heights from 150mm to 1500mm; standard functions, automatic restart, manual restart and EDM can be selected with wiring; extended range; IP69K protection.													
MODELS	BEAMS	PITCH	OPTICAL HEIGHT	HOUSING HEIGHT	RANGE	RESPONSE TIME	PFH _d	DC _{avg}	MTTF _d	CCF	Cable		NOTES
	No.	mm	mm	mm	m	ms	F/h	%	Years	Points	Em.	Rec.	
	∅, Poles												
LS2ER/0A-050K	2	500	510	770	0 to 3 / 0 to 10	3	1.71E-08	94,9	100	80	PVC cable, length 10m, ∅5,5mm, 5-pin, 0.34 mm ² For connections see Chap.: 6, Tab.: 4 Special cable lengths 15 and 50m	PVC cable, length 10m, ∅5,5mm, 8-pin, 0.34 mm ² For connections see Chap.: 6, Tab.: 1 Special cable lengths 15 and 30m	Version IP65 + IP67, in IP69K housing. Only the standard models, all functions. Temperature -10 ... 55 ° C. For dimensions, see: Chap: 10, Fig: 6 and Table: 4
LS2ER/0B-080K	3	400	810	1070		3,5	1.87E-08	94,6	100	80			
LS2ER/0C-090K	4	300	910	1170		3,5	2.02E-08	94,2	100	80			

Tab.:8; Chap.:9

LS2 SERIES SAFETY BARRIER IN IP69K TRANSPARENT HOUSING ACCESS PROTECTION MULTI-BEAM SAFETY LIGHT GRID WITH 2, 3, 4 BEAMS													
PAIRED MODELS		LS2	ER	/	0A	0B	0C	050	080	090	H		
FUNCTIONS: optical heights from 150mm to 1500mm; standard functions, automatic restart, manual restart and EDM can be selected with wiring; extended range; IP69K protection and thermostat.													
MODELS	BEAMS	PITCH	OPTICAL HEIGHT	HOUSING HEIGHT	RANGE	RESPONSE TIME	PFH _d	DC _{avg}	MTTF _d	CCF	Cable		NOTES
	No.	mm	mm	mm	m	ms	F/h	%	Years	Points	Em.	Rec.	
	∅, Poles												
LS2ER/0A-050H	2	500	510	770	0 to 3 / 0 to 10	3	1.71E-08	94,9	100	80	PVC cable, length 10m, ∅6mm, 8-pin, 0.34 mm ² For connections see Chap.: 6, Tab.: 5 Special cable lengths 15 and 50m	PVC cable, length 15m, ∅6mm, 10-pin, 0.34 mm ² For connections see Chap.: 6, Tab.: 3 Special cable lengths 15 and 30m	Version IP65 + IP67, in IP69K thermostated housing Only the standard models, all functions. Temperature -25 ... 55 ° C. For dimensions, see: Chap: 10, Fig: 6 and Table: 4
LS2ER/0B-080H	3	400	810	1070		3,5	1.87E-08	94,6	100	80			
LS2ER/0C-090H	4	300	910	1170		3,5	2.02E-08	94,2	100	80			

Tab.:9; Chap.:9

10.0 MECHANICAL DIMENSIONS, BARRIERS AND STANDARD ACCESSORIES

10.1 IP67 models

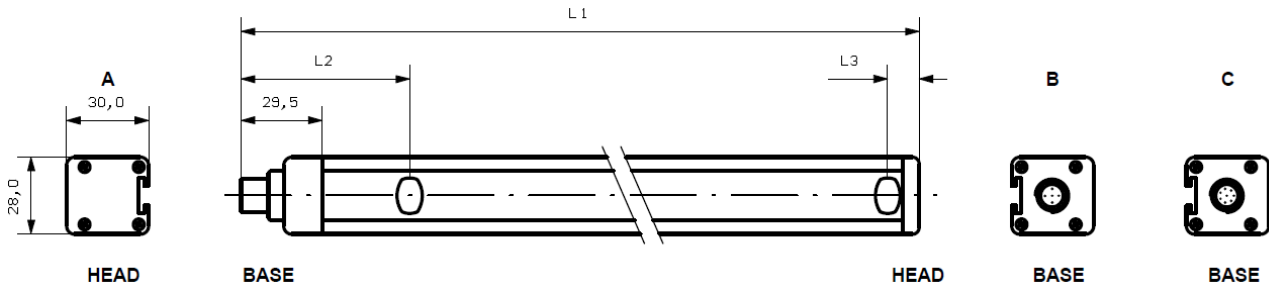

Fig.:1; Chap.:10. Dimensions of Standard, Base, Final models; view of the base and head with relevant connectors; see Tab.:1 and 3

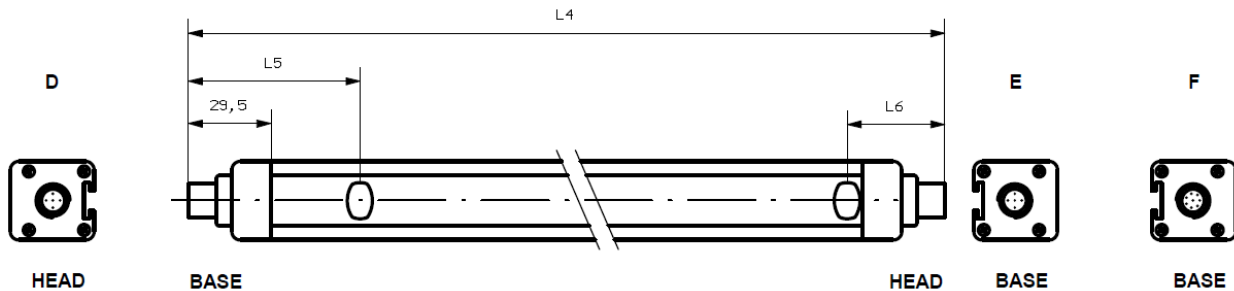

Fig.:2; Chap.:10 Dimensions of Master and Slave models; view of the base and head with relevant connectors; see Tab.:2 and 3

LS2 SERIES		DIMENSIONS OF CORTINE MODELS											Dimensions (mm)	
PAIRED MODELS		###												
		015	030	045	060	075	090	105	120	135	150	165	180	
LS2ER/**-### LS2ER/**-###B LS2ER/**-###F	Standard, Base, Final	213	363	513	663	813	963	1113	1263	1413	1563	1713	1863	L1
		61.5											L2 (first lens)	
		11											L3 (last lens)	
LS2ER/**-###M LS2ER/**-###S	Master, and Slave	236.5	386.5	536.5	686.5	836.5	986.5	1136.5	1286.5	1436.5	1586.5			L4
		61.5											L5 (first lens)	
		34.5											L6 (last lens)	

Tab.:1; Chap.:10

LS2 SERIES		DIMENSIONS OF MULTIPLE BEAMS MODELS			
PAIRED MODELS		**-###			Dimensions (mm)
		0A-050	0B-080	0C-090	
LS2ER/**-### LS2ER/**-###B LS2ER/**-###F	Standard, Base, Final	653	953	1053	L1
		102			L2 (first lens)
		51			L3 (last lens)
LS2ER/**-###M LS2ER/**-###S	Master, Slave	677	977	1077	L4
		102			L2 (first lens)
		75			L3 (last lens)

Tab.:2; Chap.:10

LS2 SERIES		TYPES OF TERMINATION AND CONNECTORS							
MODELS		LS2R (Receivers)				LS2E (Emitters)			
		View BASE	Type of connector	View HEAD	Type of connector	View BASE	Type of connector	View HEAD	Type of connector
LS2*/**-###	Standard	C	M12, 8p, M	A	-	B	M12, 5p, M	A	-
LS2*/**-###B	Base	B	M12, 5p, M	A	-	B	M12, 5p, M	A	-
LS2*/**-###F	Final	B ⁽¹⁾	M12, 5p, M	A	-	B ⁽¹⁾	M12, 5p, M	A	-
LS2*/**-###M	Master	F	M12, 8p, M	D ⁽¹⁾	M12, 5p, M	E	M12, 5p, M	D ⁽¹⁾	M12, 5p, M
LS2*/**-###S	Slave	E ⁽¹⁾	M12, 5p, M	D ⁽¹⁾	M12, 5p, M	E ⁽¹⁾	M12, 5p, M	D ⁽¹⁾	M12, 5p, M

Tab.:3; Chap.:10

 <p>M.D. Micro Detectors Strada S. Caterina, 235 41122 Modena Italy Tel. +39 059 420411 Fax +39 059 253973 www.microdetectors.com info@microdetectors.com</p>	LS2 SERIES SAFETY LIGHT CURTAIN TYPE 2	LANGUAGE
	Installation and Operation Manual	ENGLISH

NOTE: These connectors are dedicated to a communication BUS of the Master/ Slave chain, it is not permissible to access the lines, always use cord sets.

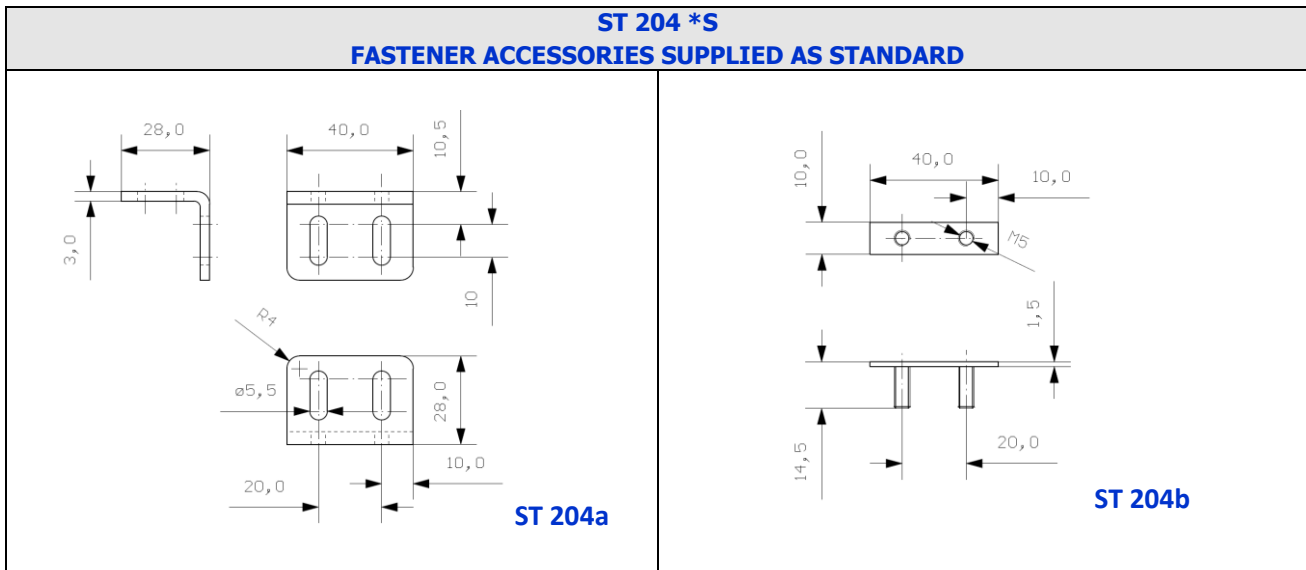

Fig.:3; Chap.: 10. L-brackets.
Supplied as standard, 4 pieces per pairs for lengths 300 to 1050, 6 pieces for lengths 1200 to 1500.

Fig.: 4; Chap.: 10. Insert with threaded pins and related bolts
Supplied as standard, in the right number for the brackets

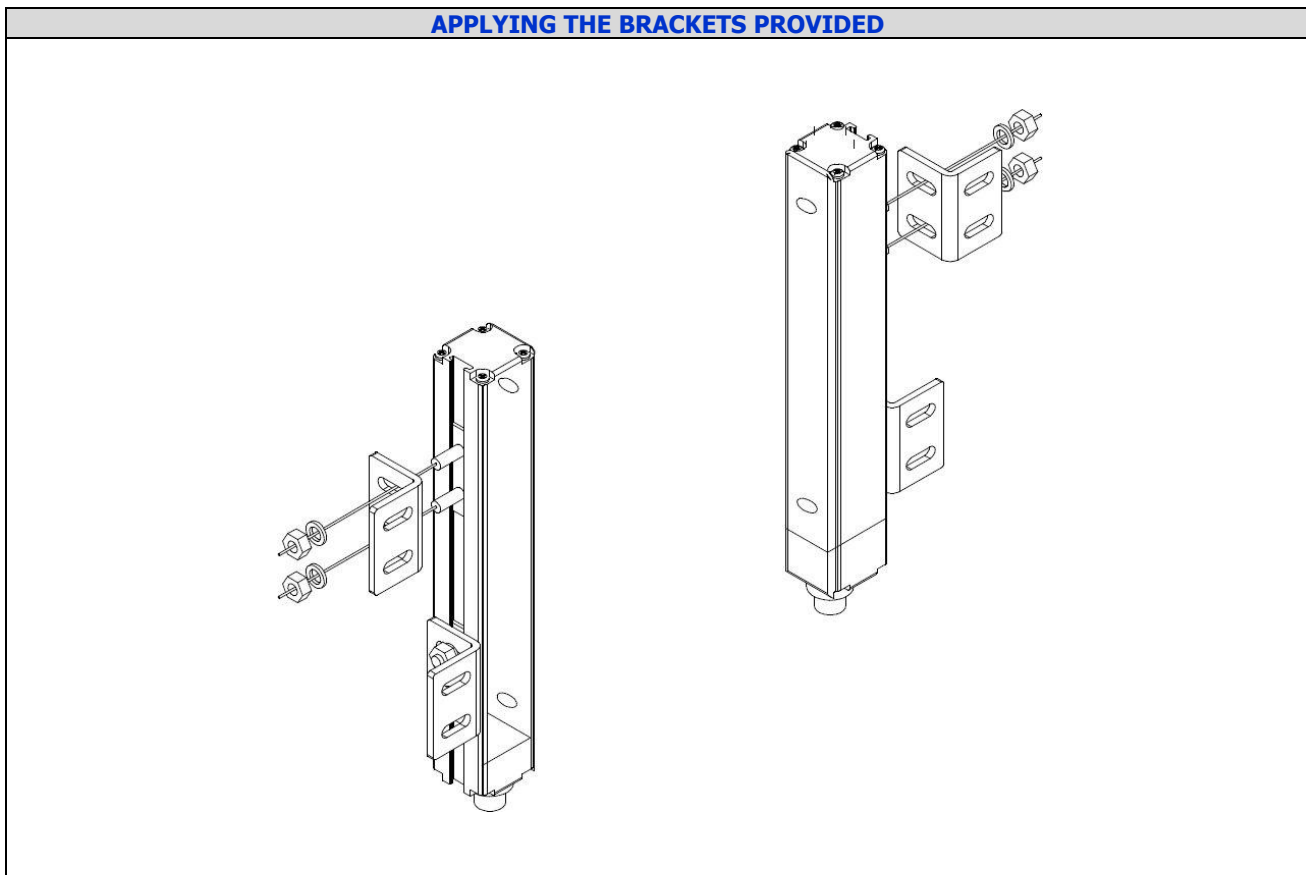

Fig.:5; Chap.:10

10.2 IP69K models

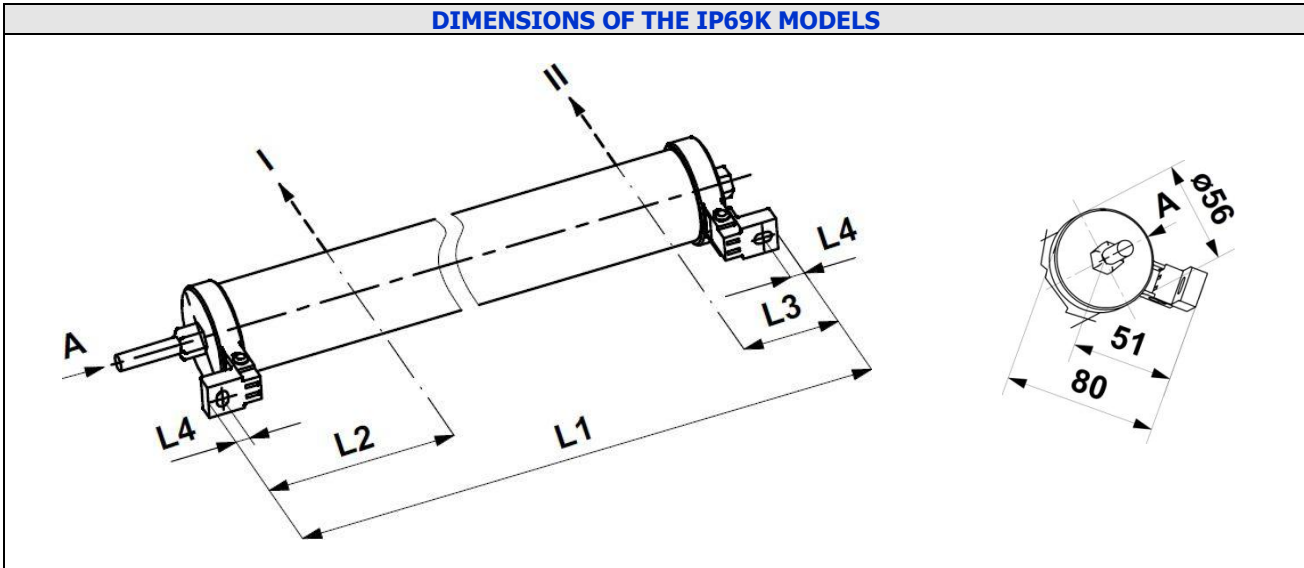

Fig.:6; Chap.:10 (I: first beam; II: last beam)
 The light curtain is supplied already fitted inside the transparent housing.
 The power cord has a standard length of 10 meters and a maximum diameter of 6 mm.
 The brackets are included.

SERIE LS2	IP69K MODELS													
	CORTINES										MULTIPLE BEAMS			
MODELS	LS2ER/30-***K LS2ER/30-***H										LS2ER/**-###K LS2ER/**-###H			
OPTIC	015	030	045	060	075	090	105	120	135	150	0A	0B	0C	
Heater Max. Power (W)	2	4	6	8	9	10	10	10	10	10	8	10	10	
Dimensions (mm)	L1	325	475	625	775	925	1075	1225	1375	1525	1675	765	1065	1165
	L2	131										171		
	L3	60										100		
	L4	8										8		

Tab.:4; Chap.:10 (The power refers to a single element, emitter or receiver).

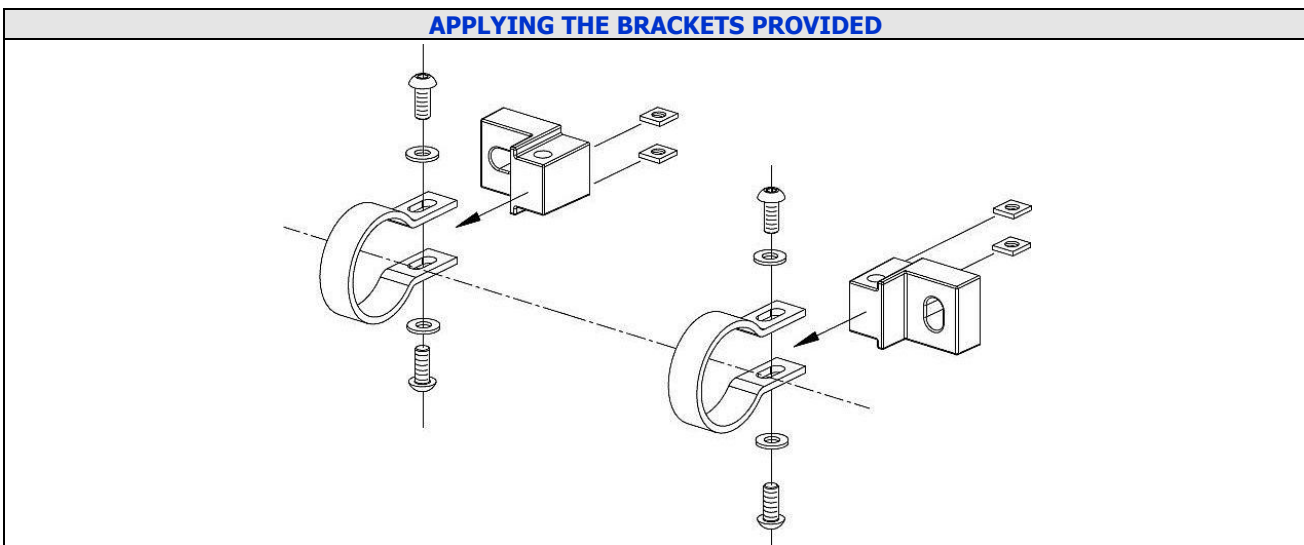

Fig.:7; Cap.:10

 Micro Detectors Italian Sensors Technology	M.D. Micro Detectors Strada S. Caterina, 235 41122 Modena Italy Tel. +39 059 420411 Fax +39 059 253973 www.microdetectors.com info@microdetectors.com	LS2 SERIES SAFETY LIGHT CURTAIN TYPE 2	LANGUAGE
		Installation and Operation Manual	

11.0 LIST OF ACCESSORIES APPLICABLE TO THIS PRODUCT

MODEL	DESCRIPTION
M12 SUPPLY CONNECTORS FOR EMITTER OR RECEIVER BASE MODELS	
CD12M/OH-050A3	M12 connector, straight, 5 poles, female, 5m PVC cable
CD12M/OH-100A3	M12 connector, straight, 5 poles, female, 10m PVC cable
CD12M/OH-150A3	M12 connector, straight, 5 poles, female, 15m PVC cable
CD12M/OH-250A3	M12 connector, straight, 5 poles, female, 25m PVC cable
CD12M/OH-500A3	M12 connector, straight, 5 poles, female, 50m PVC cable
CD12M/OH-050C3	M12 connector, right-angle, 5 poles, female, 5m PVC cable
CD12M/OH-100C3	M12 connector, right-angle, 5 poles, female, 10m PVC cable
CD12M/OH-150C3	M12 connector, right-angle, 5 poles, female, 15m PVC cable
M12 SUPPLY CONNECTORS FOR STANDAR RECEIVER OR MASTER RECEIVER MODELS	
CD12M/OE-050A1	M12 connector, straight, 8 poles, female, 5m PVC cable
CD12M/OE-100A1	M12 connector, straight, 8 poles, female, 10m PVC cable
CD12M/OE-150A1	M12 connector, straight, 8 poles, female, 15m PVC cable
CD12M/OE-250A1	M12 connector, straight, 8 poles, female, 25m PVC cable
CD12M/OE-400A1	M12 connector, straight, 8 poles, female, 40m PVC cable
CD12M/OE-050C1	M12 connector, right-angle, 8 poles, female, 5m PVC cable
CD12M/OE-100C1	M12 connector, right-angle, 8 poles, female, 10m PVC cable
CD12M/OE-150C1	M12 connector, right-angle, 8 poles, female, 15m PVC cable
M12/M12 EXTENSION CABLE FOR INTERCONNECTION AMONG MASTER/SLAVE/FINAL ELEMENTS	
CDP12/OH-003AC	Extension M12/M12 connector, straight, 5 poles, female/female, 0.3m PVC cable
CDP12/OH-030AC	Extension M12/M12 connector, straight, 5 poles, female/female, 3m PVC cable
CDP12/OH-050AC	Extension M12/M12 connector, straight, 5 poles, female/female, 5m PVC cable
CDP12/OH-100AC	Extension M12/M12 connector, straight, 5 poles, female/female, 10m PVC cable
CDP12/OH-250AC	Extension M12/M12 connector, straight, 5 poles, female/female, 25m PVC cable
TEST RODS	
ST 2230	Test rod Ø 30mm
ST 2240	Test rod Ø 40mm
ST 2250	Test rod Ø 50mm
BRACKETS SUPPLIED AS STANDARD	
ST 204 4S	Kit of 4 L brackets and related insert and bolts, see Fig.:3 and 4; Chap.:10
ST 204 6S	Kit of 6 L brackets and related insert and bolts, see Fig.:3 and 4; Chap.:10
SPECIAL BRACKETS	
ST 206 4S	Kit of 4 safety light curtain fastening, curved L-brackets to facilitate angular orientation, inserts, bolts
ST 206 6S	Kit of 6 safety light curtain fastening, curved L-brackets to facilitate angular orientation, inserts, bolts
ST 207 S	Kit of 4 safety light curtain fastening, brackets with rotation on pin, inserts, bolts
VIBRATION DAMPING SUPPORTS	
ST 4V S	Kit of 4 vibration-damping supports, for models with optical height of 150
ST 8V S	Kit of 8 vibration-damping supports, for models with optical height from 300 to 1050
ST 12V S	Kit of 12 vibration-damping supports, for models with optical height from 1200 to 1500
TRACKING SYSTEM	
STL 01 S	Specific tracking LASER for alignment of the safety light curtains with profile 28x30mm
RELAY INTERFACE MODULE	
SB 300	Safety relay module for DIN bar, two 24VDC relays, two output NO contact (single), one output NO contact (series) for EDM. Max. switching voltage 250V AC/DC, contact rating 690VA@230V _{AC} , 72W@24V _{DC} .

Tab.:1; Chap.:11

12.0 CONTENT OF THE PACKAGE

Each single kit package corresponding to a pair code contains:

- A pair of safety light curtains composed of an Emitter and a Receiver.
- An adequate number of brackets and inserts for the height of the model.
- A CD ROM containing multilingual technical documentation, including the declaration of conformity.
- Brief multilingual installation sheet.

 <p>M.D. Micro Detectors Strada S. Caterina, 235 41122 Modena Italy Tel. +39 059 420411 Fax +39 059 253973 www.microdetectors.com info@microdetectors.com</p>	LS2 SERIES SAFETY LIGHT CURTAIN TYPE 2	LANGUAGE
	Installation and Operation Manual	ENGLISH

13.0 CHECKING THE SYSTEM

13.1 Purpose of the checks.

The purpose of the checks described below is to confirm the safety requirements of the national or international prescriptions, particularly the safety requirements of the Machinery Directive or the Directive for operators of work equipment (conformity with EU directives).

These checks are also for detecting interference on the protection effect caused by undesired sources of light, including sensors of the same type and in general by photoelectric sensors, reflections and other particular environmental factors. These checks must necessarily be carried out.

13.2 Checks prior to commissioning

- It must be possible to enter the danger area only via a route that breaks the beam of light between the Emitter and the Receiver.
- It must be impossible to climb over, crawl under or be able to avoid the optical beam between the Emitter and Receiver.
- It must not be possible to stop inside the protected area without this condition being detected.
- It must not be possible to operate the system start/restart controls from within the protected area.
- All the protection devices must be correctly mounted and firmly locked in position with systems that require specific tools or keys for handling.
- The maximum time for stopping the dangerous movements of the machine must be known with certainty or verified, and this time, added to the other portions of time of the entire chain of safety devices, must have been used to determine the safety distance.
- The protection device must be effective in all the machine's operating modes.
- The dangerous movement must be stopped if a different operating mode is selected.
- Ensure that the machine's operators have been educated by qualified personnel or by the person in charge of machine safety before beginning work. The person in charge of machine safety is responsible for this training.
- Make sure that the documentation is visible/available for the machine's operators.
- Verify the effectiveness of the system of protection, carrying out a test as indicated hereunder in this Chap.:13.4 "Regular checks on the effectiveness of the protection device".

13.3 Regularity of the checks by qualified personnel

- Check the system in conformity with current national prescriptions and within the terms they require.
- Check that there have been no modifications to or tampering with the protection devices after commissioning.
- Check the system again as if for commissioning if any major changes have been made to the machine or the protection device, or after installing new equipment or replacing the protection devices.

13.4 Regular checks on the effectiveness of the protection device

The state and effectiveness of the protection device must be checked regularly, for example daily or each time before beginning work, with the specific test rod, by authorized and appointed persons.

- Check that there is no damage or dirt on the surface of the optical windows; scratches, scoring and misting can deteriorate the resolution of the safety light curtain.
- If necessary clean the optical surface with a moist antistatic cloth, do not use alcohol, solvents or abrasive substances.
- Slowly slide the test rod, of diameter corresponding to the resolution of the safety light curtain, in a perpendicular direction to the optical beams in the following positions:
 - directly upstream from the Emitter and any diverter mirrors.
 - in the intermediate between the Emitter and Receiver and if necessary in the intermediate of sections of beams diverted by mirrors.
 - immediately upstream from the Receiver

The following result must be obtained:

- as long as the test rod is located inside the area identified by the optical windows, the safety light curtains must stay in the DARK and it must not be possible to create any danger.

In the case of multi-beam safety light curtains, the DARK state refers to interception of single beams that must be tested individually.

14.0 CE DECLARATION OF CONFORMITY

The safety light curtains of the family of LS2 have been produced in conformity with the following directives:

- Machinery directive 2006/42/EC
- EMC directive 2004/108/EC

You can find the complete version of the CE declaration of conformity on the internet website:

[http:// www.microdetectors.com](http://www.microdetectors.com)

 <p>M.D. Micro Detectors Strada S. Caterina, 235 41122 Modena Italy Tel. +39 059 420411 Fax +39 059 253973 www.microdetectors.com info@microdetectors.com</p>	LS2 SERIES SAFETY LIGHT CURTAIN TYPE 2		LANGUAGE
	Installation and Operation Manual		ENGLISH

15.0 GUARANTEE

All new LS2 systems are guaranteed by M.D. Micro Detectors for a period of 24 (twenty-four) months under normal working conditions, against defects due to faulty materials and workmanship.

During the aforesaid period, M.D. Micro Detectors promises to replace faulty parts free of charge.

This guarantee covers both material and labour.

M.D. Micro Detectors reserves the right to decide whether to repair equipment or replace it with equipment of the same type or having the same characteristics.

The validity of this guarantee is subject to the following conditions:

- The user must notify M.D. Micro Detectors of the fault within twenty-four months following the date of delivery of the product.
- The equipment and all parts thereof must be in the condition in which they were supplied by M.D. Micro Detectors.
- The defect or malfunction must not arise directly or indirectly from:
 - Improper use;
 - Non-observance of the instructions for use;
 - Negligence, inexperience, improper maintenance;
 - Repairs, modifications and adjustments carried out by personnel not authorised by M.D. Micro Detectors, tampering, etc.;
 - Accidents or collisions (also during transportation or due to acts of God);
 - Other reasons for which M.D. Micro Detectors cannot be held responsible.

Repairs will be carried out at M.D. Micro Detectors's laboratories, to which the material must be consigned or forwarded; transport costs and any damage or loss of material during transportation will be charged to the Customer.

All replaced products and parts are property of M.D. Micro Detectors.

M.D. Micro Detectors does not recognise any other form of guarantee or rights other than those expressly stated above; no requests for compensation for damages incurred for costs, suspension of activities or any other events or circumstances related in any way to malfunctioning of the product or any parts thereof will be taken into consideration.

In order to ensure the correct operation of the photoelectric barrier, careful and full compliance with all the rules, instruction and warnings stated in this manual is essential. M.D. Micro Detectors declines all responsibility for events arising from non-compliance with all or part of the aforesaid instruction.